

Next-Generation Control Communications for Power Stations - Architecture and Protection

John E. Fuller

AT&T Services

Infrastructure Planning and Optimization

(see last page for contact info)

Presented To:

Protection Engineers Group

March 25, 2015



Power Station Communications Architecture and Protection- Overview



- **Contemporary Power Grid Architectures**
- **"Smart Grid"**
- **General Communication Options and Protection Requirements**
- **U.S. Standards Requirements/Revisions**
- **Example Modern Protection Architectures**

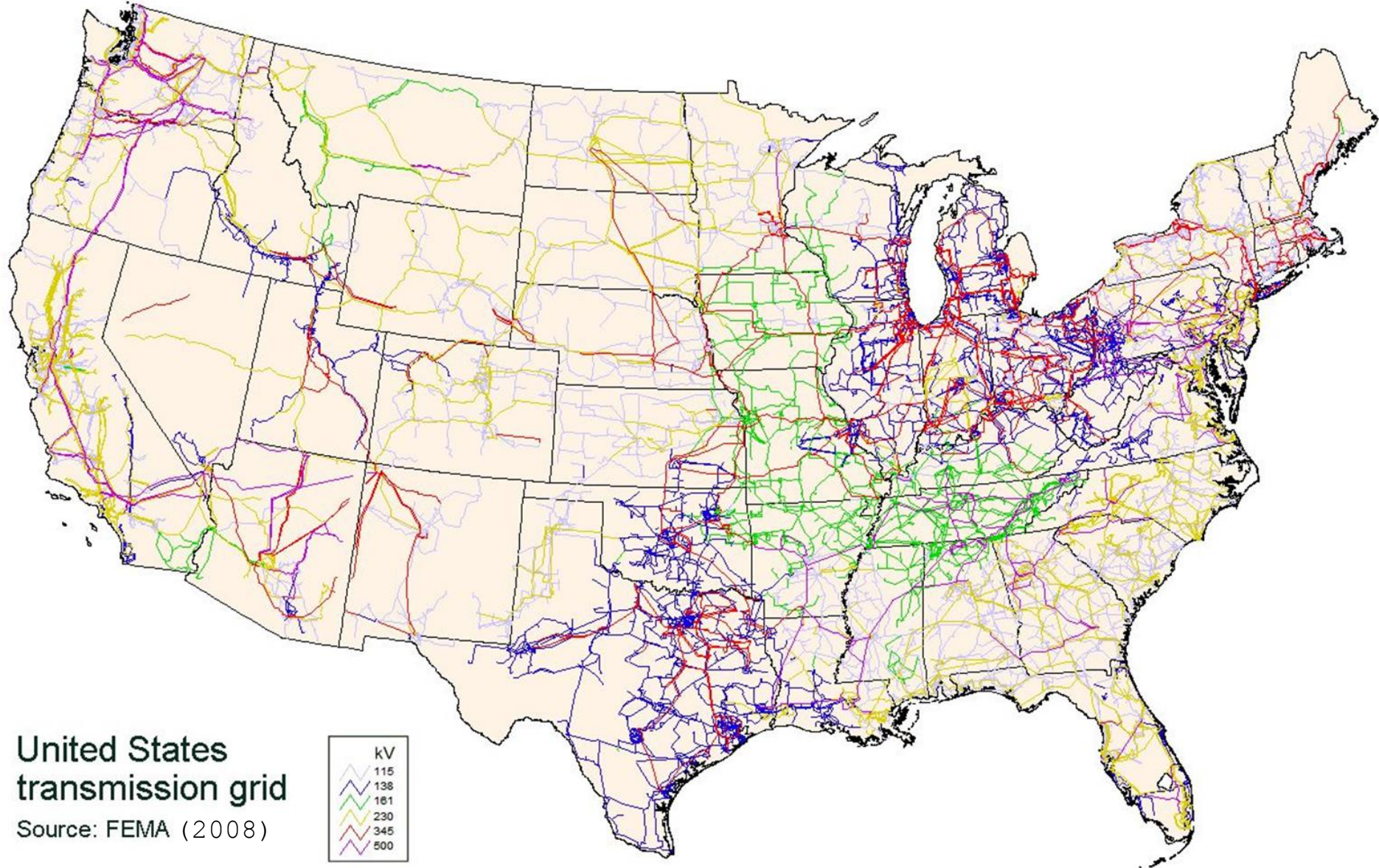

United States transmission grid

Source: FEMA (2008)

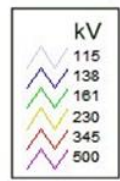

Transmission-Level Power Sources

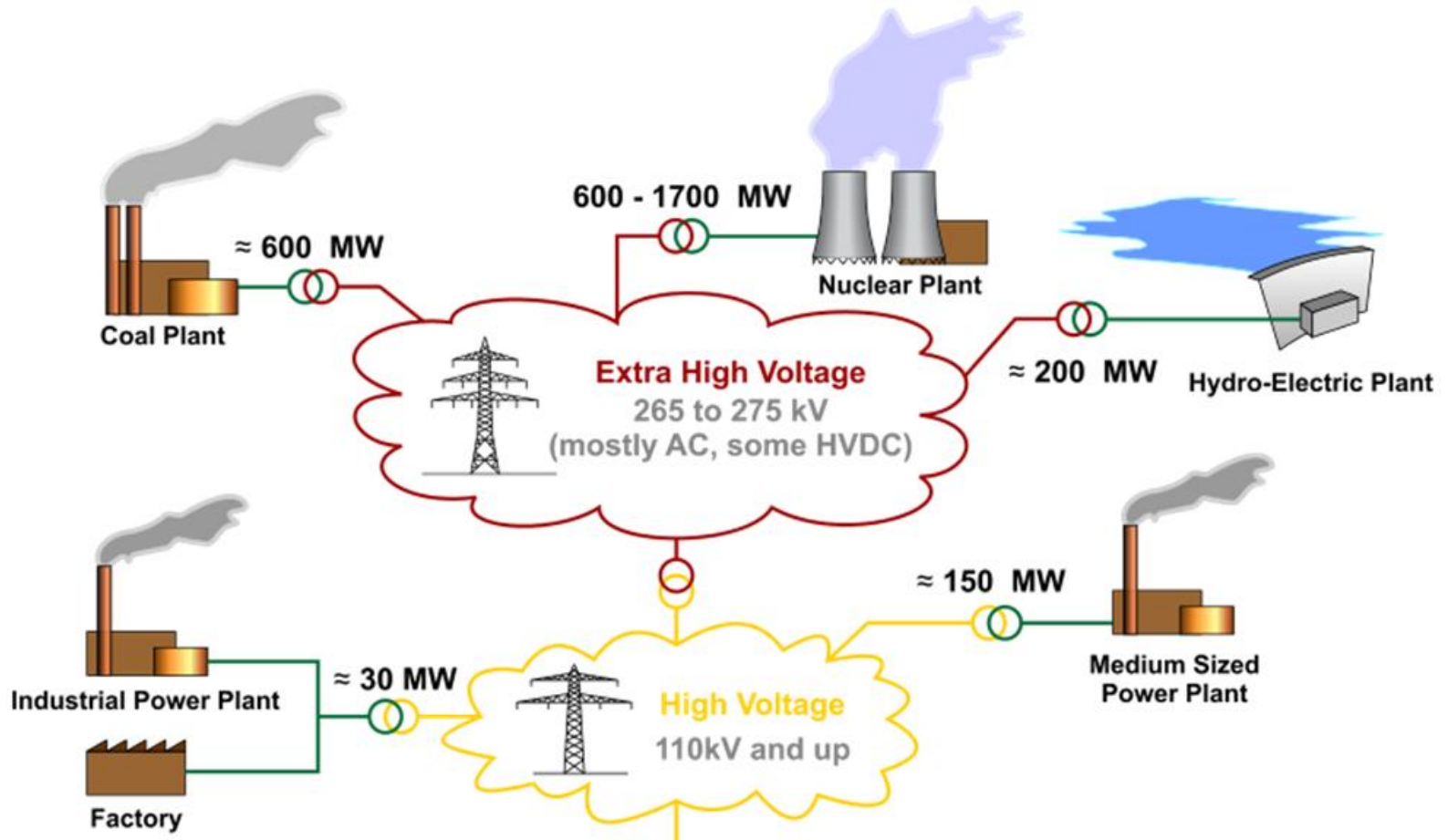

Distribution-Level Sources

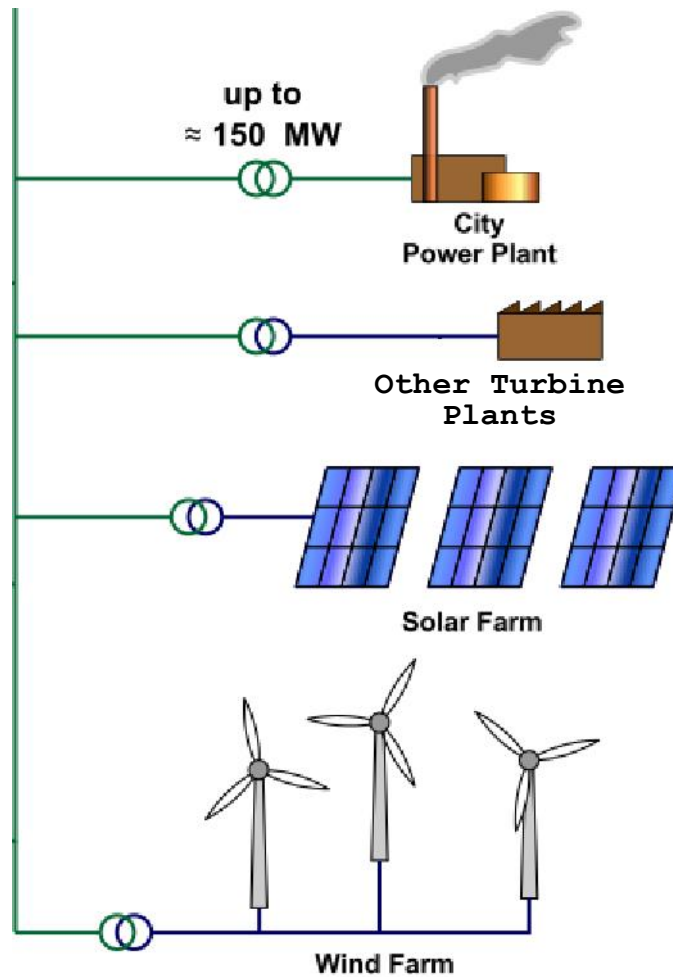

Overall Grid

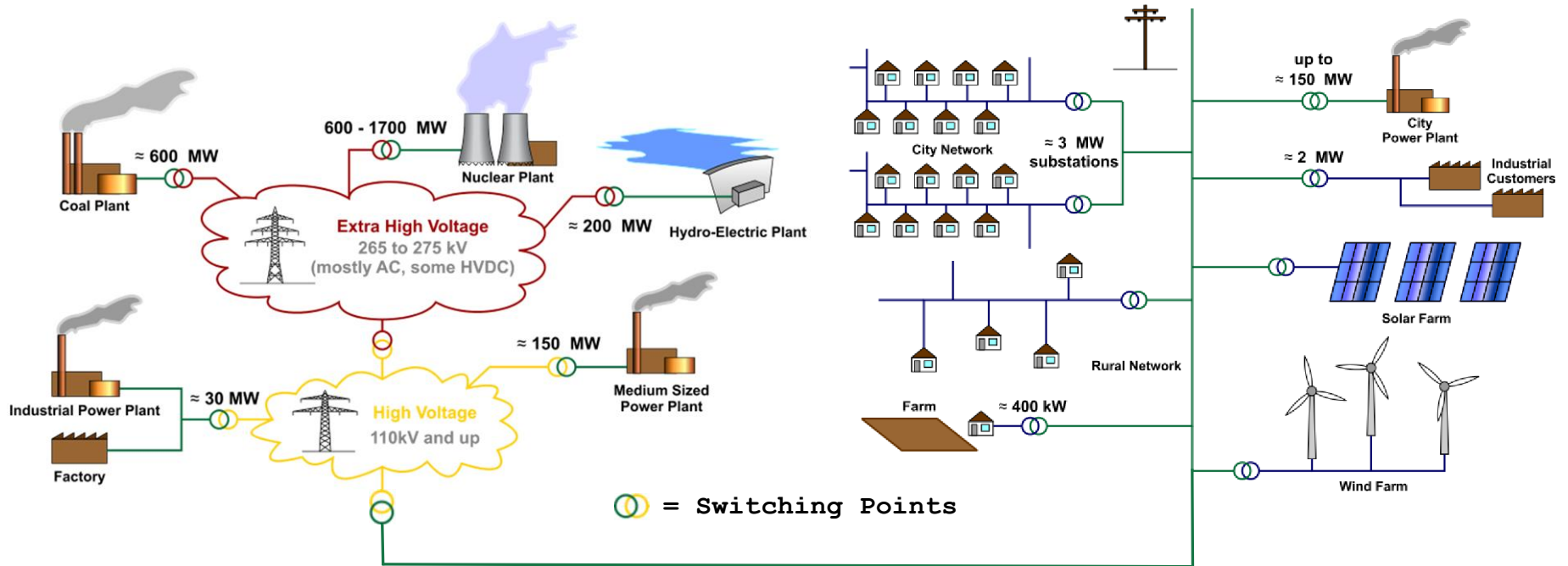



General Architecture Overview

- **Transmission**
- **Distribution**
- **Switching**
- **Generation**
- **Traditional**
 - **Fossil**
 - **Hydro**
 - **Nuclear**
- **Contemporary (generally smaller scale)**
 - **Wind**
 - **Photovoltaic**
 - **Other**

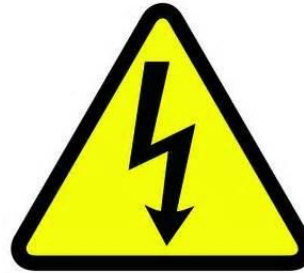

What is “Smart Grid”?



An infrastructure that creates a more flexible, resilient, and responsive electrical grid, which relies largely on reliable communications to:

- **Manage shifting load and supply effectively**
 - Time-of-day demand peaking
 - Cloud cover and weather variations on solar and wind sources
 - Social demand triggers
- **Minimize critical failures**
 - Loss of heat or air conditioning just when it is most needed
 - Rolling blackouts triggered by space weather or sabotage
- **Balance the electrical power system and reduce cost per kWh.**



"Smart" Grid

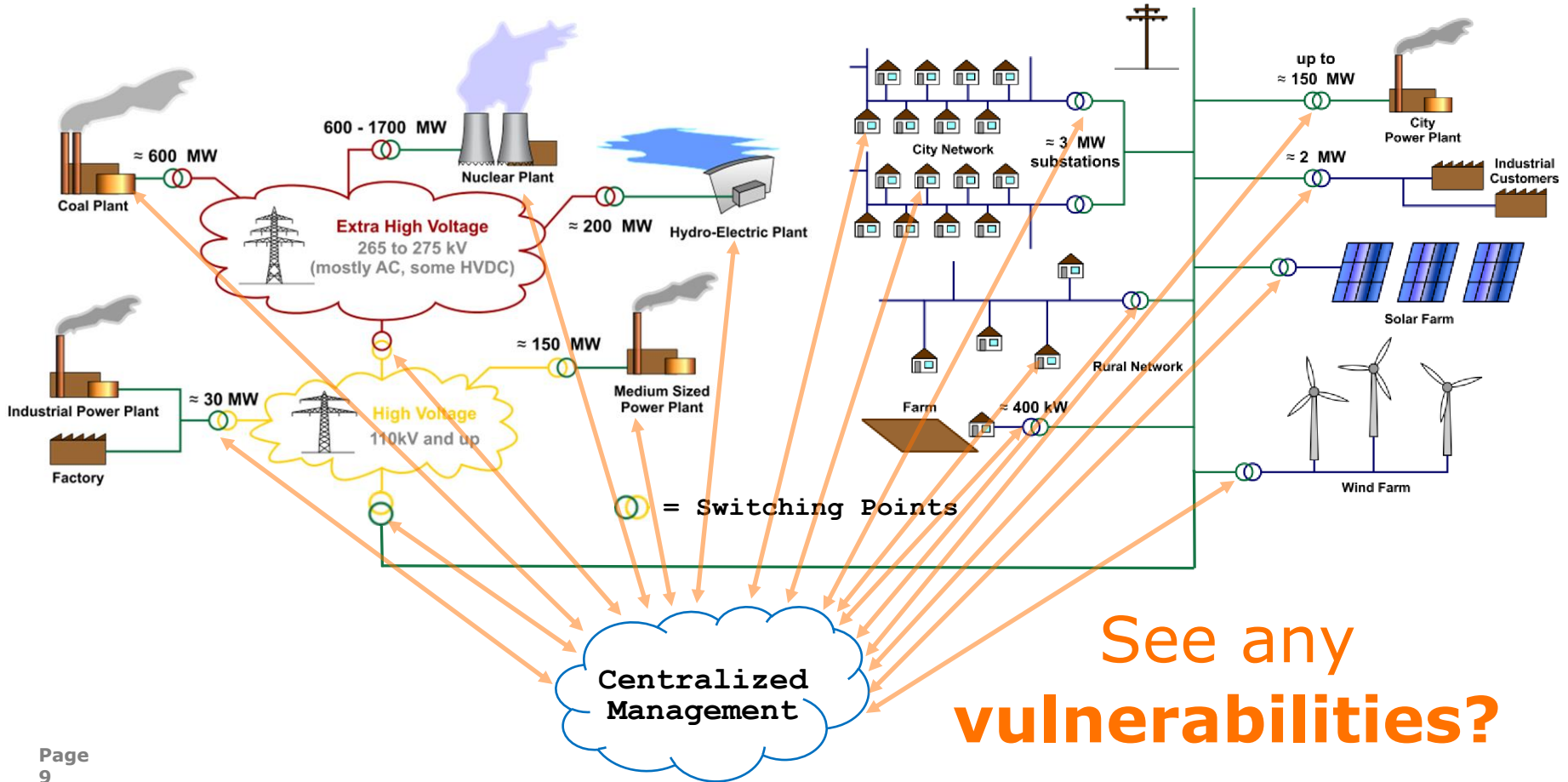

Grid Communications Requirements



- **RELIABLE**
 - Immune to environmental disturbers
 - Lightning
 - Wind/flood
 - "Space weather"
 - Redundancy / Alternate routes
 - Maintainability
- **RESPONSIVE**
 - Latency matched to function
 - Legacy transport (DS0, DS1) <6 ms envelope delay
 - Private IP networks, envelope delay 2 ms to ?
 - Leased line over IP networks, up to 120+ ms envelope delay- ?
- **COST EFFECTIVE**

Grid Communications Media



- **RADIO**
 - Point-to-Point (microwave)
 - Low latency
 - Possible high cost (distance and terrain)
 - Weather sensitivity
 - Satellite (high latency)
 - Cellular (low cost, medium latency, limited coverage)
- **DIRECT FIBER**
 - Low latency (private network)
 - Architecture-dependent cost (distance and new construction)
 - Best available reliability (including space weather immunity)
- **LEASED LINES**
 - Variable media and cost
 - Latency concerns (IP transport)
- **POWER LINE CARRIER**
 - Highly architecture-dependent
 - Range, cost, and EMC challenges

Communications Protection



- **RADIO SYSTEMS (P-P, Satellite, Cellular)**
 - Various industry specifications (not addressed here)
- **DIRECT FIBER**
 - Limited requirements (e.g. IEEE Std 487.2)
 - GPR/EPR resistant
 - Compatible with all power routes (OPGW, OPTical Ground Wire)
- **LEASED LINES**
 - Direct fiber or metallic transport
 - IEEE 487 Suite Requirements (US, some international)
- **POWER LINE CARRIER**
 - Various industry specifications (not addressed here)

U.S. Power Station Protection Standards



IEEE Std. 367-2012, IEEE Recommended Practice for Determining the Electric Power Station Ground Potential Rise and Induced Voltage from a Power Fault

- Definition and reference, and miscellaneous updates/corrections
- Recognition of transferred GPR/EPR potentials from power stations via conductive objects in the vicinity. (Clauses 9.5, 9.8, and Annex G)

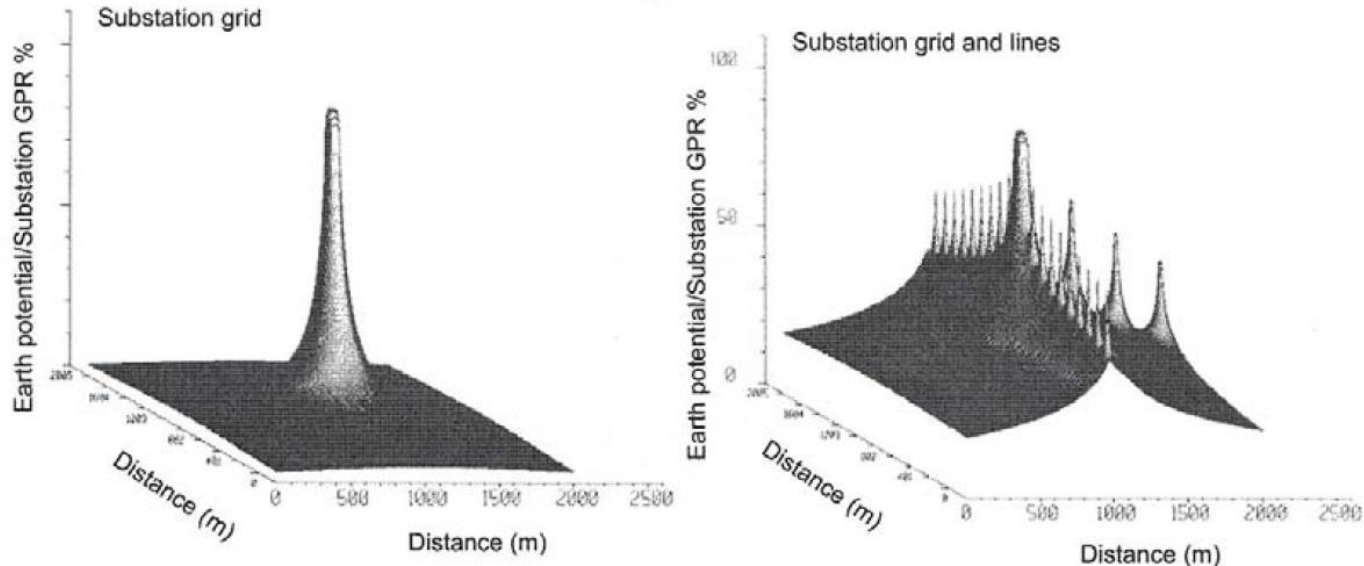

Figure G6 - 3D graph showing the zone of influence of the substation with [right] and without lines [left] for the 300/3 000 $\Omega \cdot m$ soil structure

U.S. Power Station Protection Standards

IEEE 487 Series



- **Recently revised and converted into a “dot series” of standards**
 - **Std. 487** (core) DRAFT *Standard for the Electrical Protection of Communication Facilities Serving Electric Supply Locations - **General Considerations***
 - **Std. 487.1-2014** *IEEE Standard for the Electrical Protection of Communication Facilities Serving Electric Supply Locations Through the Use of **On-Grid Isolation** [modular devices]*
 - **Std. 487.2-2013** *...**Optical Fiber Systems***
 - **Std. 487.3-2014** *...**Hybrid Facilities** [copper and fiber in loop]*
 - **Std. 487.4-2013** *...**Neutralizing Transformers**- editorial changes only*
 - **Std. 487.5-2013** *...**Isolation Transformers** [discrete devices]- editorial*

IEEE Std 487 Revisions



- **487 (core)**
 - Definition and subtending standard reference updates
 - Updated wireless tower diagrams and references
 - Clause 7.1, Updated Circuit Types table and examples :

Table 1—Service Types

Type	Definition
Type 1	Services requiring either dc transmission or ac and dc transmission used for: 1-Basic exchange telephone service or private line, or both, voice telephone service (phone, tie lines, trunks, radio control, dc alarms, telegraph, etc.) and DDS (ac and dc transmission). 2-Telemetry, supervisory control, etc.
Type 2	Private line services requiring ac or dc transmission, or both, used for pilot wire protective relaying, or dc tripping.
Type 3	Private line services requiring only ac transmission used for telemetry, supervisory control, data, etc.
Type 4	Private line services requiring only ac transmission used for audio tone protective relaying.
Type 5	Digital services with equipment subject to latency, or synchronization, time delay issues. May include services such as DS1 digital transmission, TDM, packet-based, T1, ISDN PRI, xDSL private line transport services, DDS (ac transmission only) and ethernet.

NOTE—Various other classifications may be used.

IEEE Std 487 Revisions



- **487.1 (core)**
 - Definition and reference updates
- **Std. 487.2-2013 ...*Optical Fiber Systems***
 - Requirements for direct optical fiber circuits (no copper in serving loop)
 - Replaces direct fiber portions of IEEE Std 1590-2009 (cancelled)
- **Std. 487.3-2014 ...*Hybrid Facilities*** [copper and fiber in loop]
 - Requirements for “hybrid fiber” isolation systems
 - Replaces hybrid fiber portions of IEEE Std 1590-2009 (cancelled)
 - First-time inclusion of recommendations for placement of CFJ (Copper to Fiber Junction) inside the GPR/EPR Zone of Influence (ZOI)...

IEEE Std 487.3-2014 Highlights



Clause 5- Hybrid fiber-optic isolation systems

5.1 Topologies for hybrid optical fiber isolation systems

There are four basic topologies for a hybrid fiber-optic isolation system. In each topology, configuration requirements for the OEI portion of the installation are the same. The configuration requirements for the CFJ are different in each topology and vary depending on CFJ equipment grounding design criteria.



IEEE Std 487.3-2014 Highlights

Clause 5.1- Topologies for hybrid optical fiber isolation systems

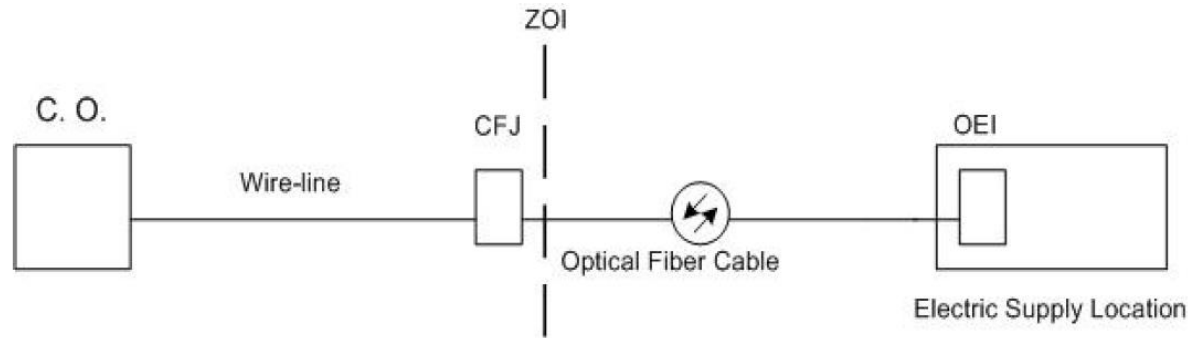

Figure 3—Typical set up for topology 1

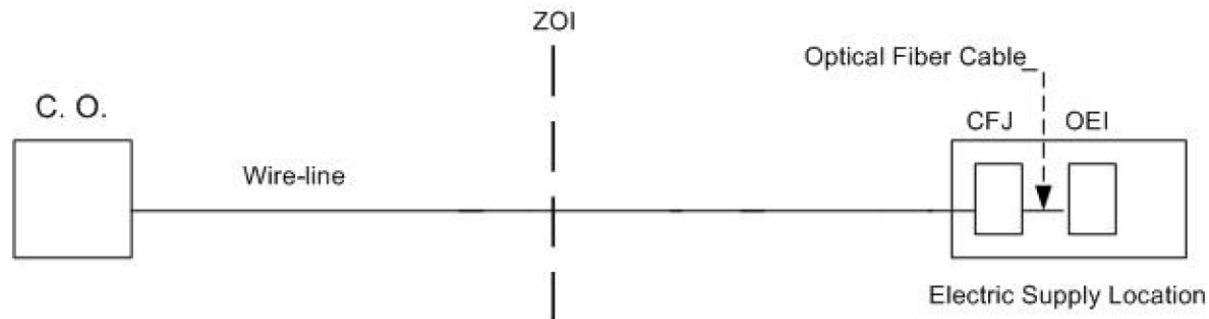

Figure 4—Typical set up for topology 2

IEEE Std 487.3-2014 Highlights



Clause 5.1- Topologies for hybrid optical fiber isolation systems

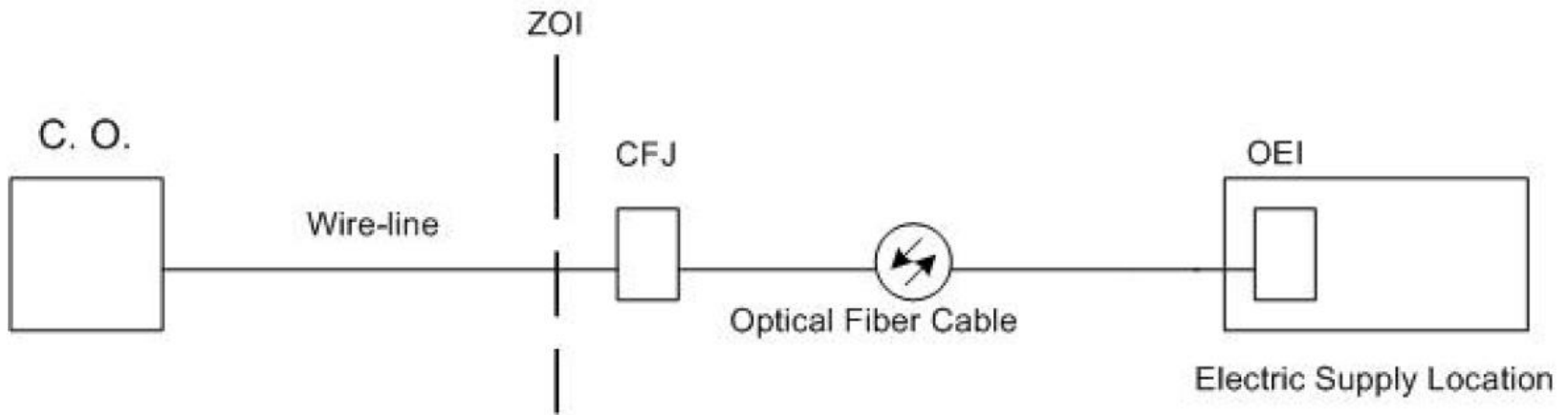
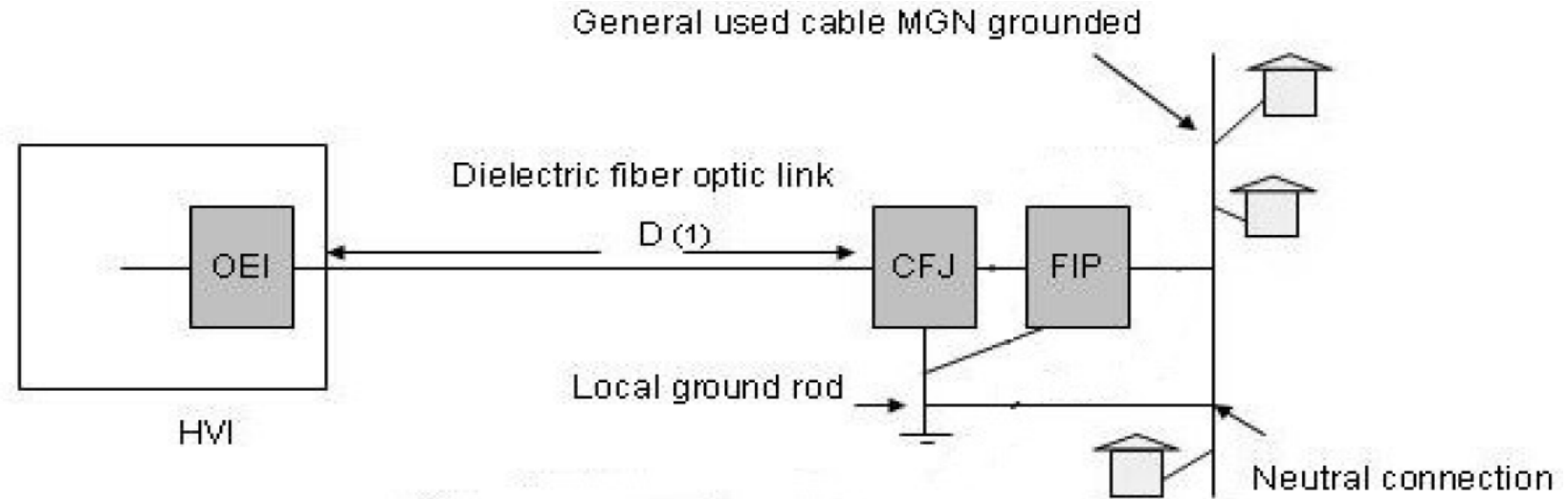

Figure 5—Typical set up for topology 3



IEEE Std 487.3-2014 Highlights

Clause 5.1- Topologies for hybrid optical fiber isolation systems



Note 1—See items e) and f) in 8.4.4.

Note 2—May be restricted to SPO Class C. See IEEE Std 487.

Figure 8—Simplified protection configuration for topology 4

IEEE Std 487.3-2014 Highlights



Clause 8- Design recommendations for CFJ installations

8.1 CFJ at electric power stations

8.2 CFJ located outside the ZOI of an electric supply location

8.3 CFJ located within the ZOI of an electric supply location

8.4 Conditional deployment of CFJ with electronics or pair protection that requires grounding by design

8.5 Conditional deployment of CFJ with electronics or pair protection that does not require grounding by design



Example Modern Protection Architectures

See the attached Excel file for an example of current High Voltage Protection architectures used by a telecommunications service provider.

These architectures utilize recommendations from the IEEE 487 series standards just reviewed. Follow links provided on sheet 1 for illustrations associated with each.



Microsoft Excel
Worksheet

QUESTIONS, COMMENTS?...

John E. Fuller , P.E.
Network EMI, Electrical & High Voltage Protection Support
Principal Design Engineer
AT&T Services
Infrastructure Planning and Optimization
Email jf2307@att.com
Ofc. 423-581-5116