



**P**ROTECTION  
**E**NGINEERS  
**G**ROUP

HUNTSVILLE, AL - MARCH 13-15, 2018

# Surge Protection for DC Power: Things to Consider

Presented by:  
**Vincent Crevenat**  
*Dir of Engineering*  
Citel

## Surge protection for DC power: things to consider.

The discussion will be about the trend of powering telecom equipment with DC power supplies and the selection of surge protection devices (SPDs) to protect this equipment. Consideration to the way the DC power supply is referenced to ground must be given as it can lead to catastrophic failure in case of wrong selection. It can be related to potential risk of TOV (Temporary Over-Voltage) created by various fault situations and leading to the overstress of a incorrectly selected SPD. The SPD arrangement itself can be different as well if a middle grounding point is available for example. The way the power supply behaves when a fault (e.g. short circuit or ground fault) is detected will have a significant safety impact when the SPD reaches its end of life. The new DC pulsed power supplies have some specific technical aspects that must be considered when selecting a SPD. For example, the leakage current could be not any more negligible as it can be for regular DC installations. Typical SPD are usually using limiting type components such as MOVs. But how these components behave when connected to regular DC or pulsed DC power supplies must be considered. What are other possible SPD constituents should be considered? Finally, how to select the proper surge rating of a DC SPD, Is it different than selecting an AC power SPD?

## What is a DC power source?

- Linear

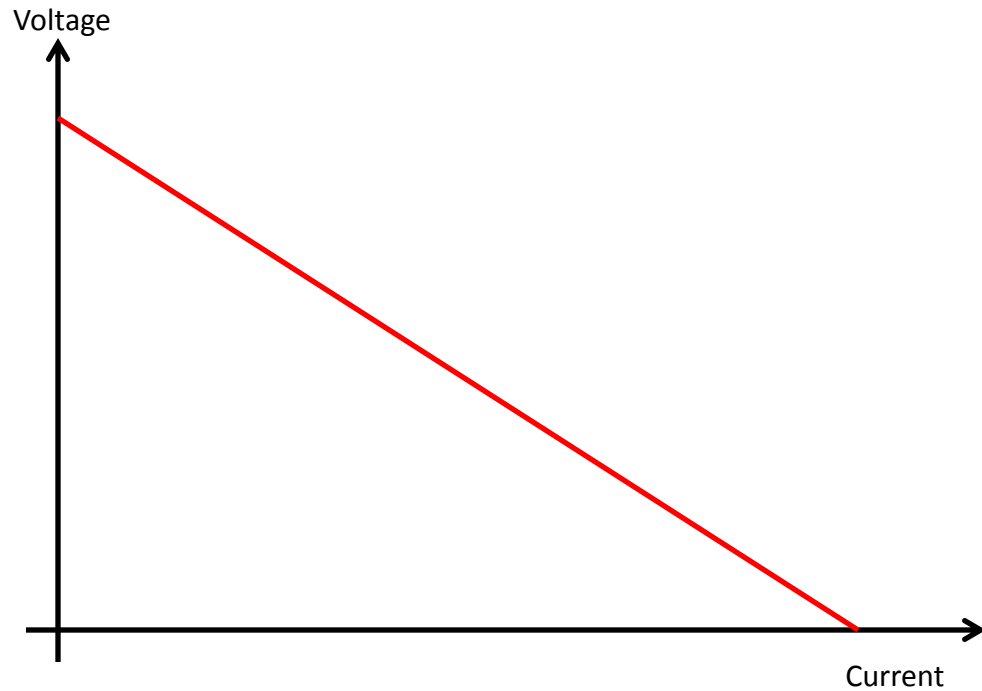

- Non linear

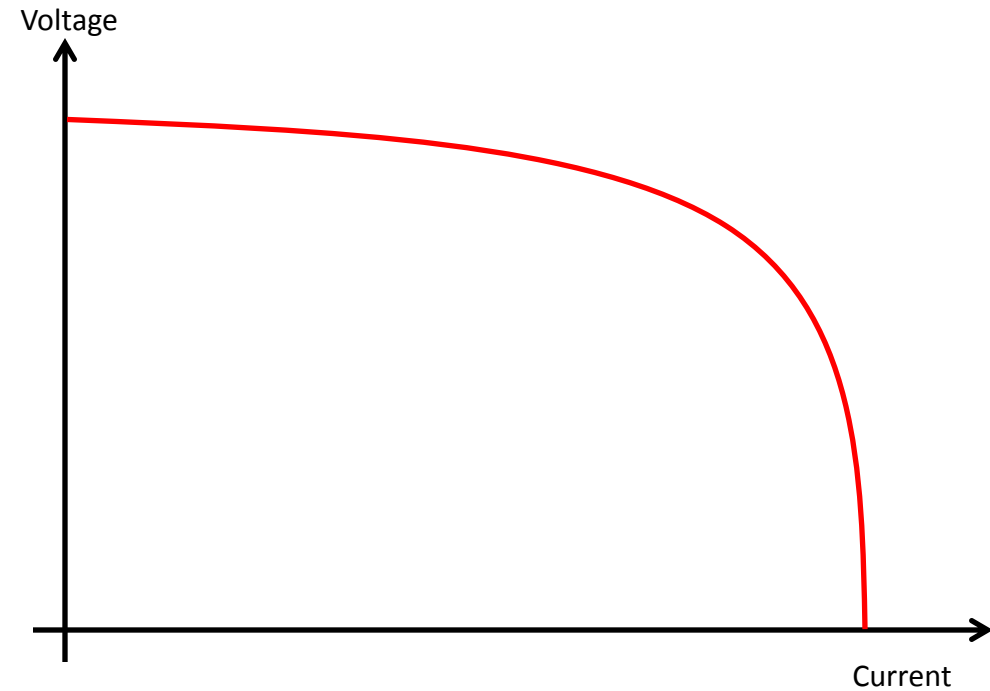

## Are all batteries acting similar?

- LEAD

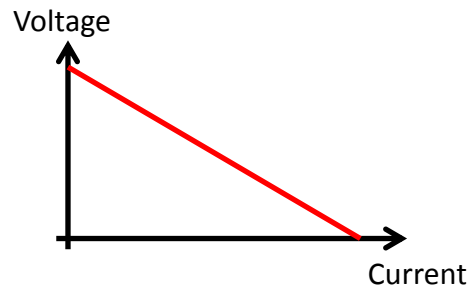

- li-Ion, LIPO ect.

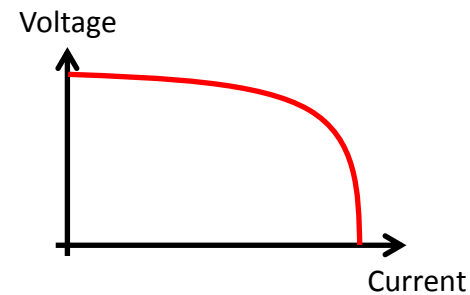

# What is a DC power source?

- Standard

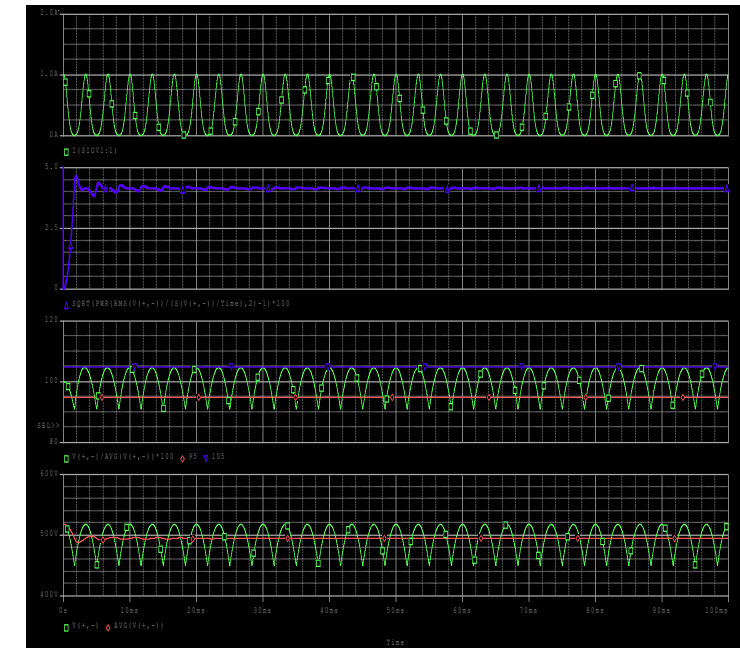
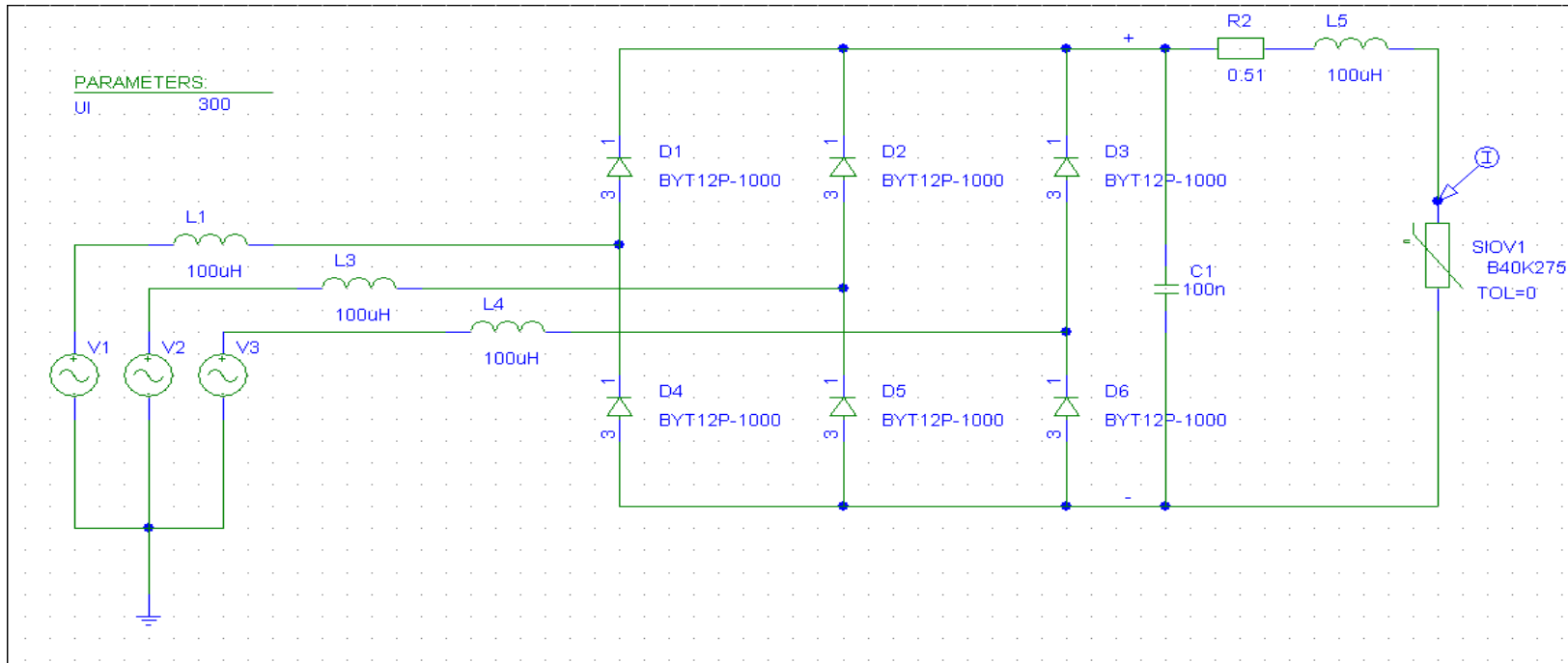
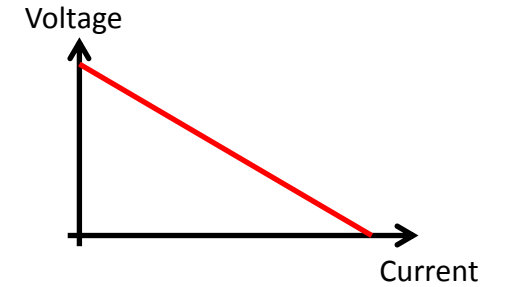

## What is a DC power source?

- Regulated

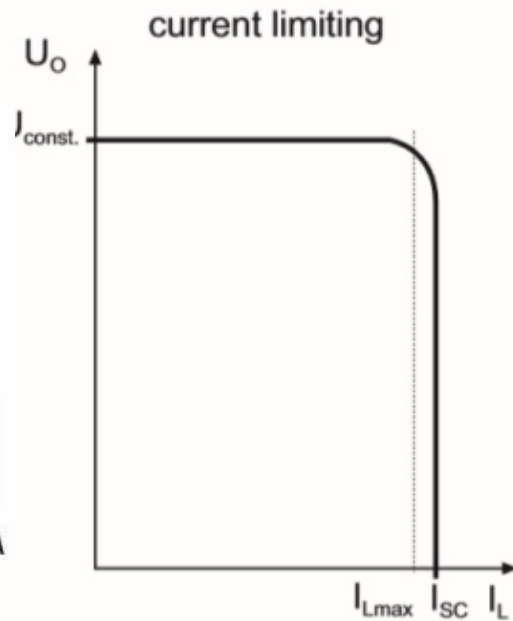
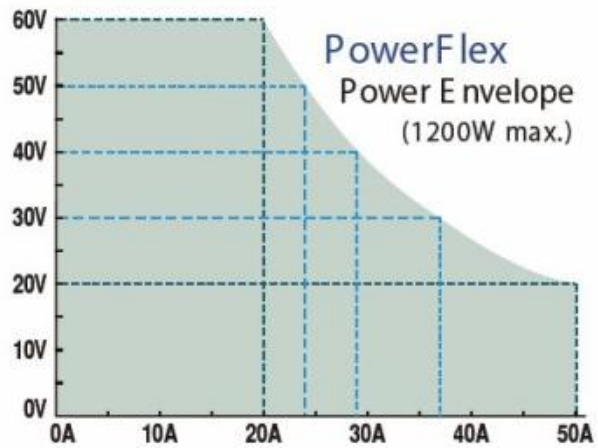

- Fold back

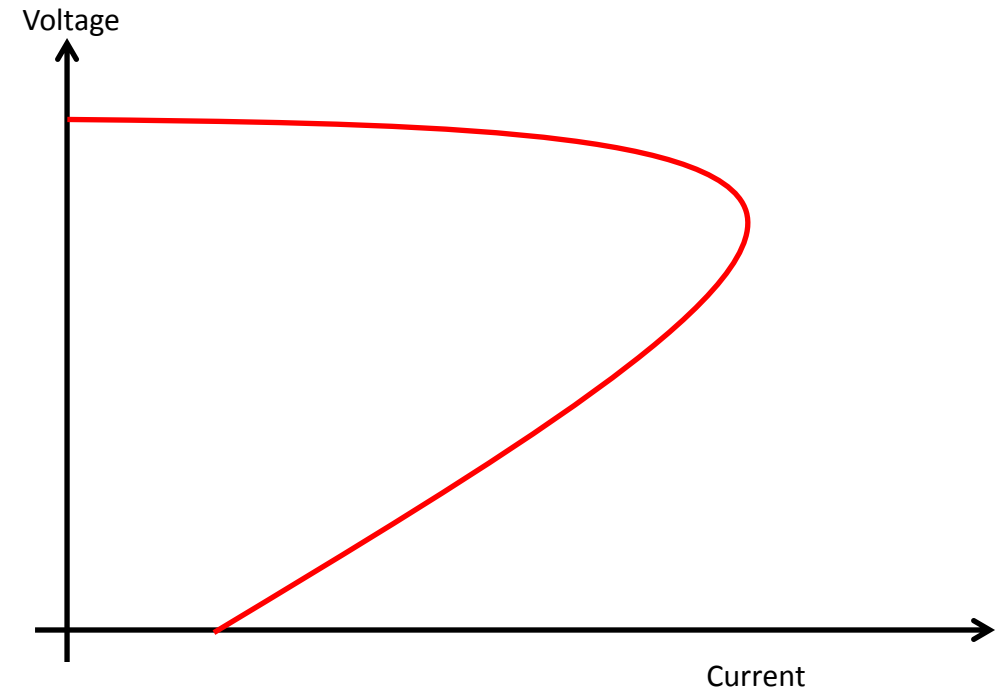

## What is a DC power source?

- Regulated

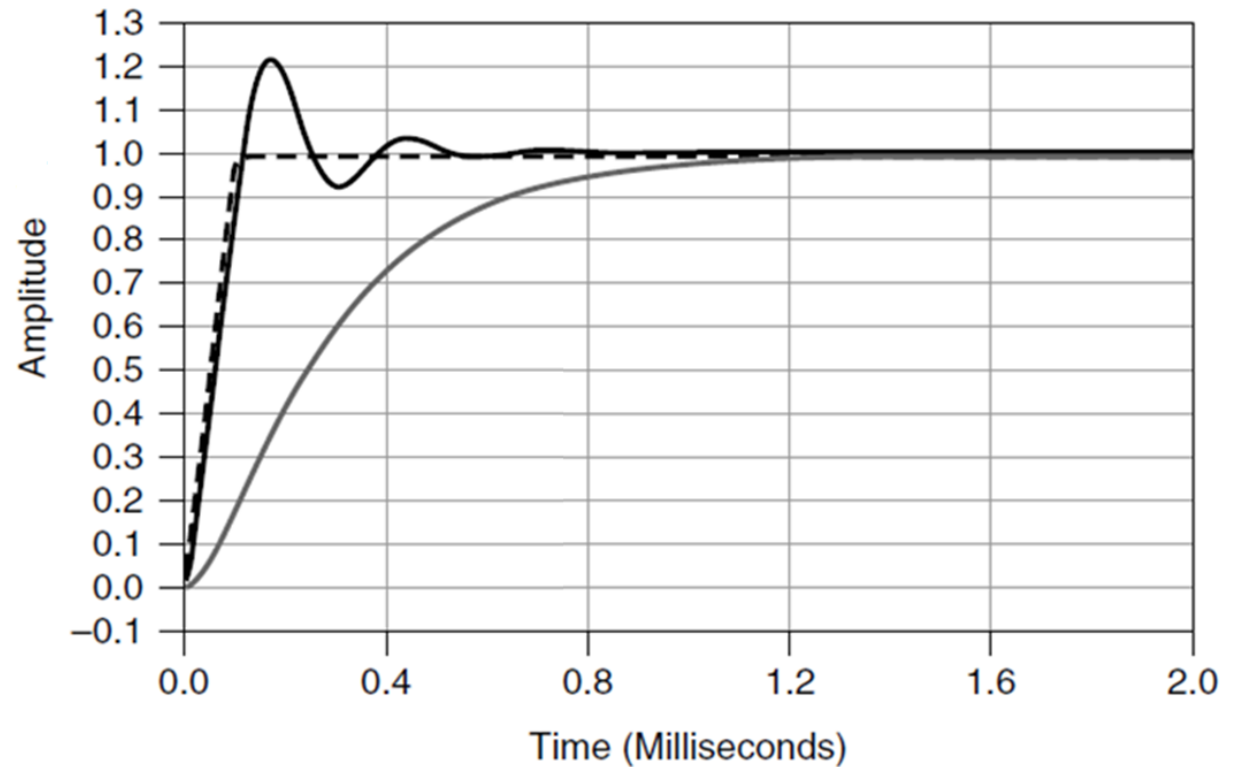
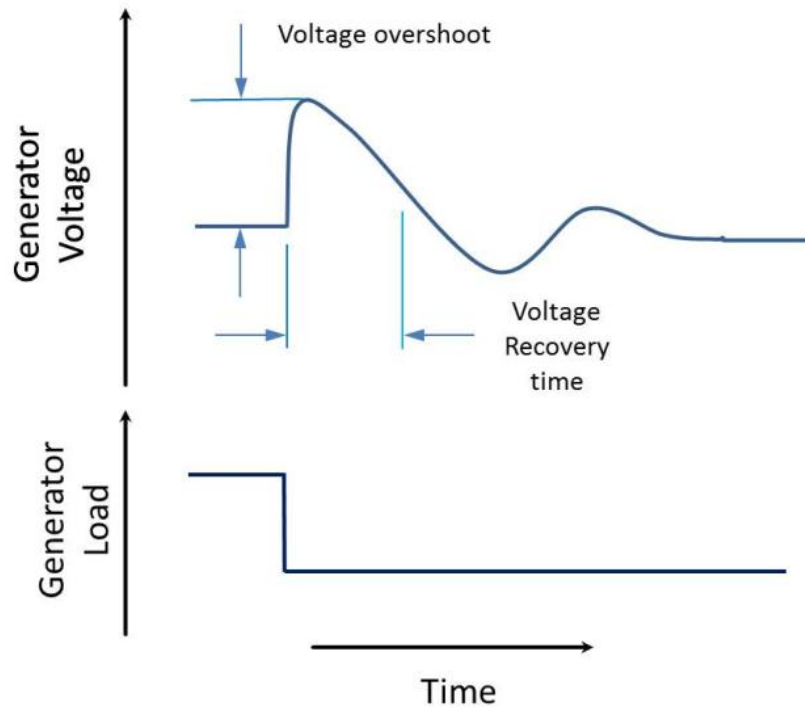

## What is a DC power source?

- Switching

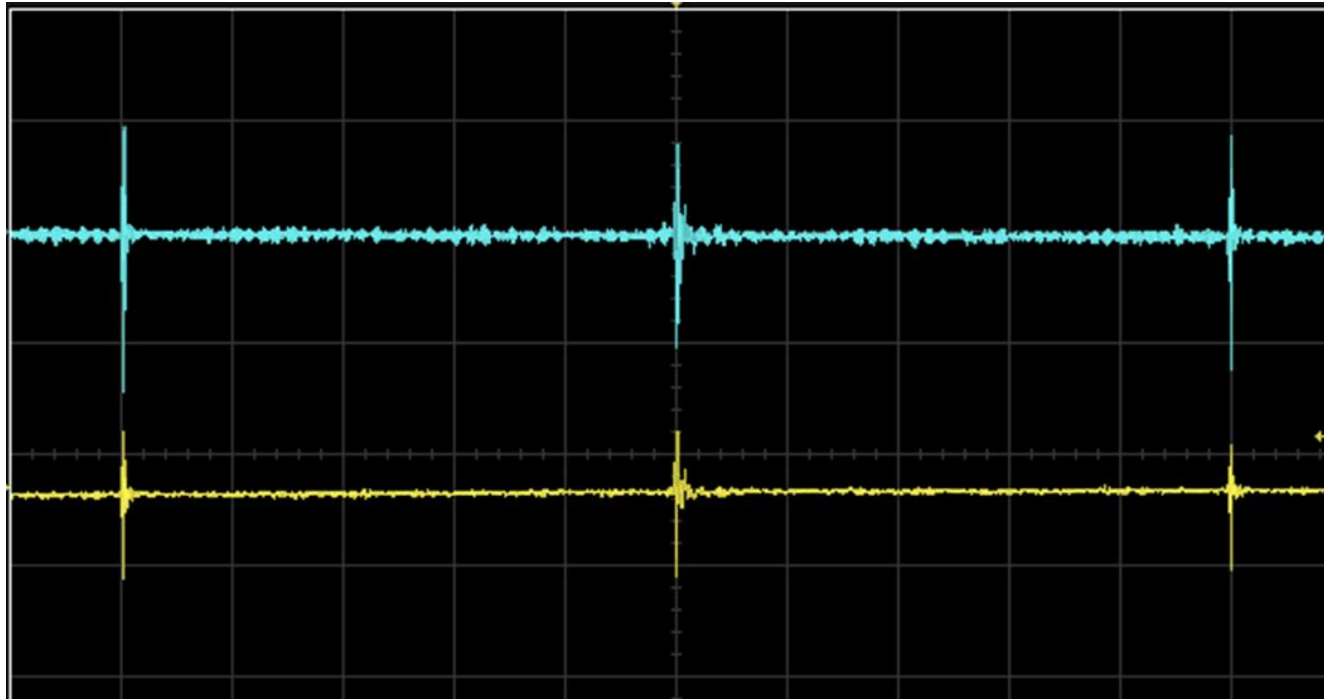



## What is a DC power source?

- Basic points of interest for SPD selection
  - Type of U/I curve
  - Regulation (Response time, Overshoot)
  - Time constant
  - HF
  - Ripples
  - Short circuit current
  - ...

## 48V, 16kW DC regulated power supply

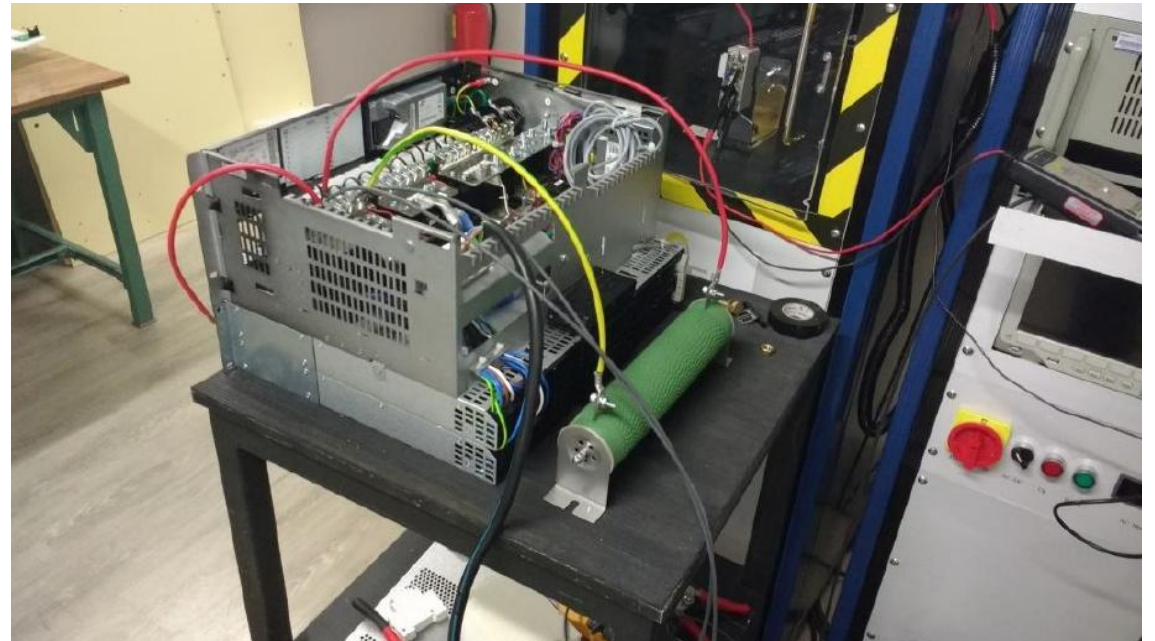
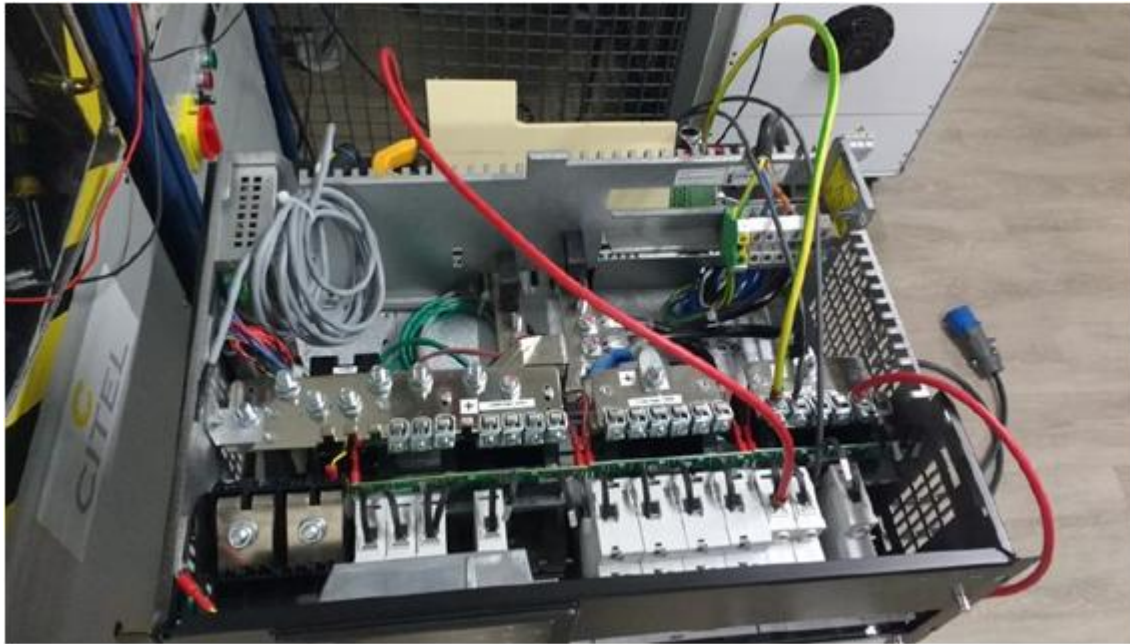

## AC/DC Converter/inverter technology about AC/DC separation

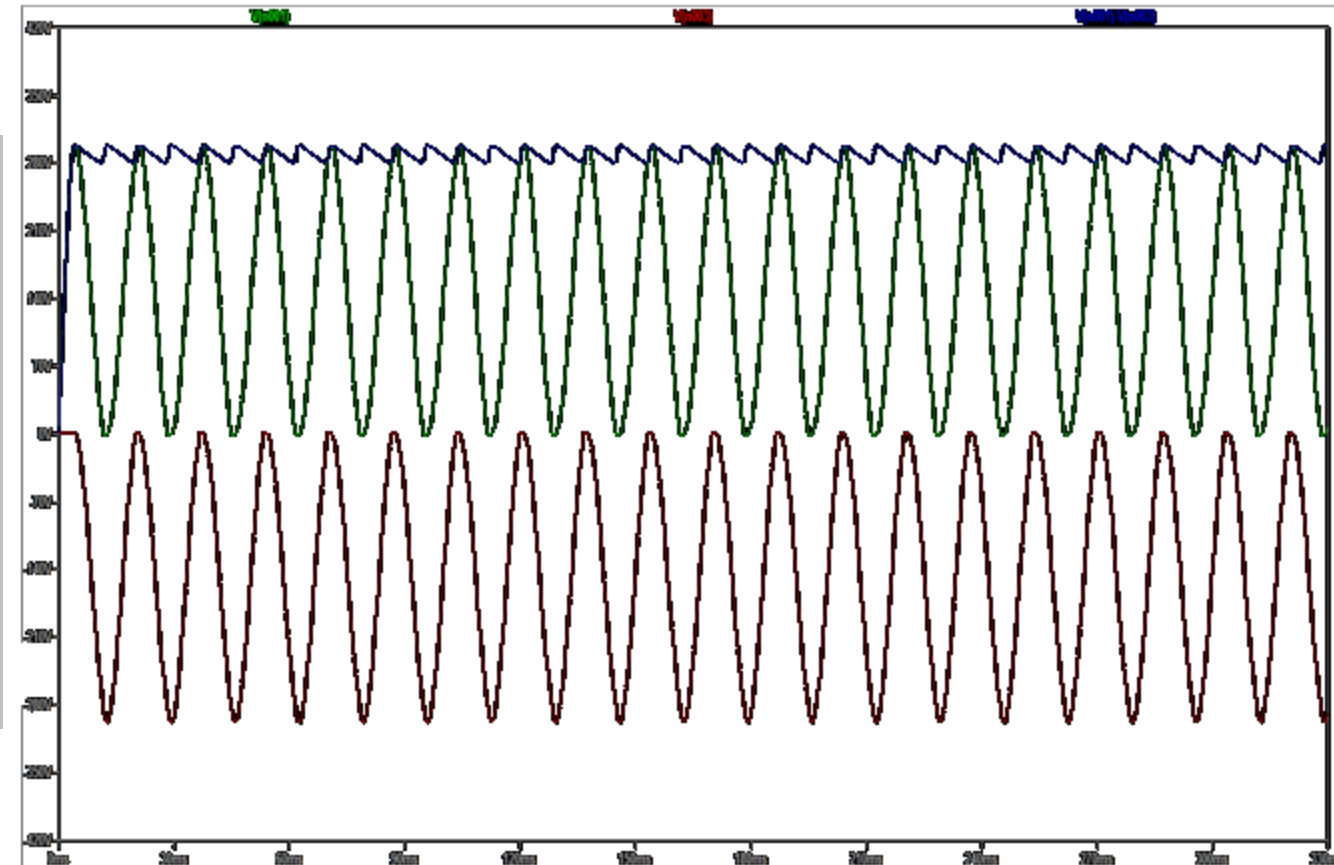
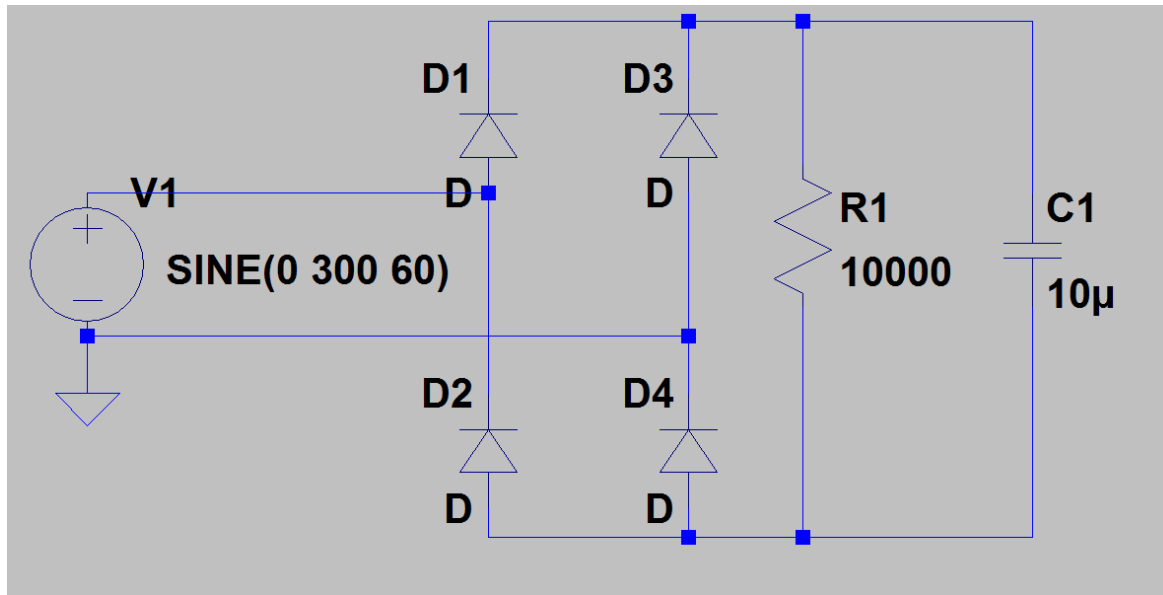

# AC/DC Converter/inverter technology about AC/DC separation

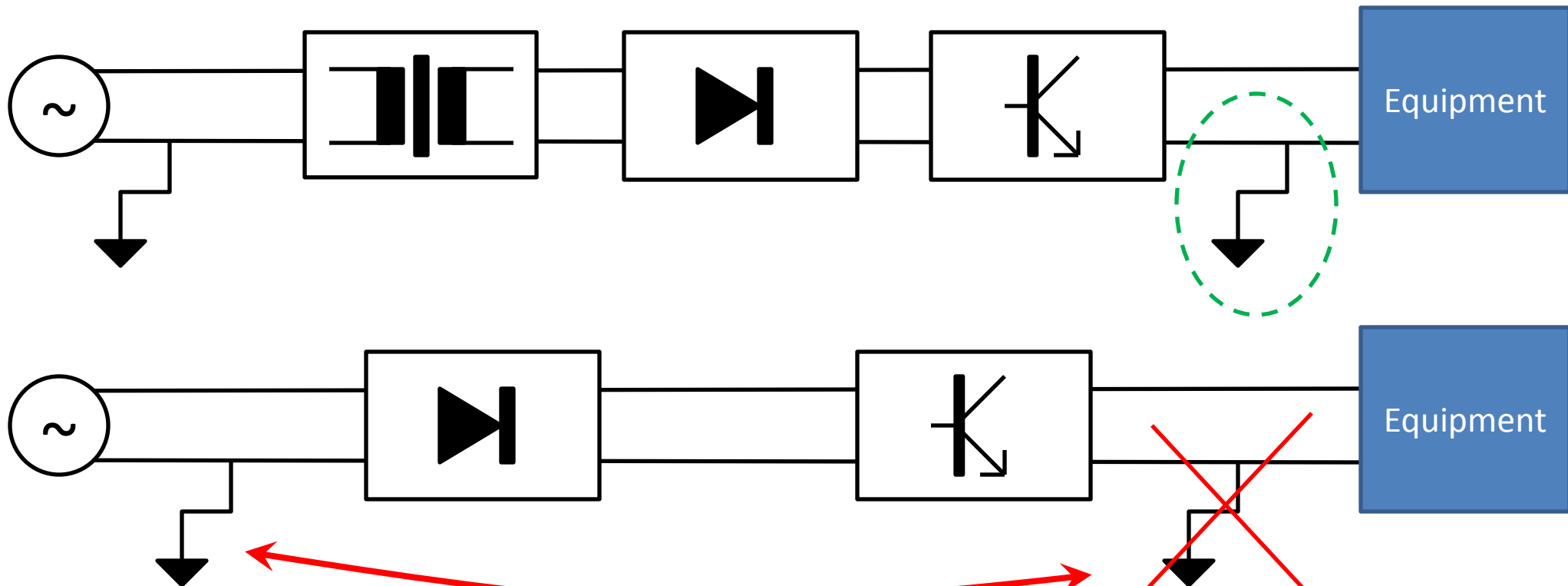

Except if 1 pulse rectifier (and/or equivalent using Neutral as the reference)

## AC/DC Converter/inverter technology about AC/DC separation

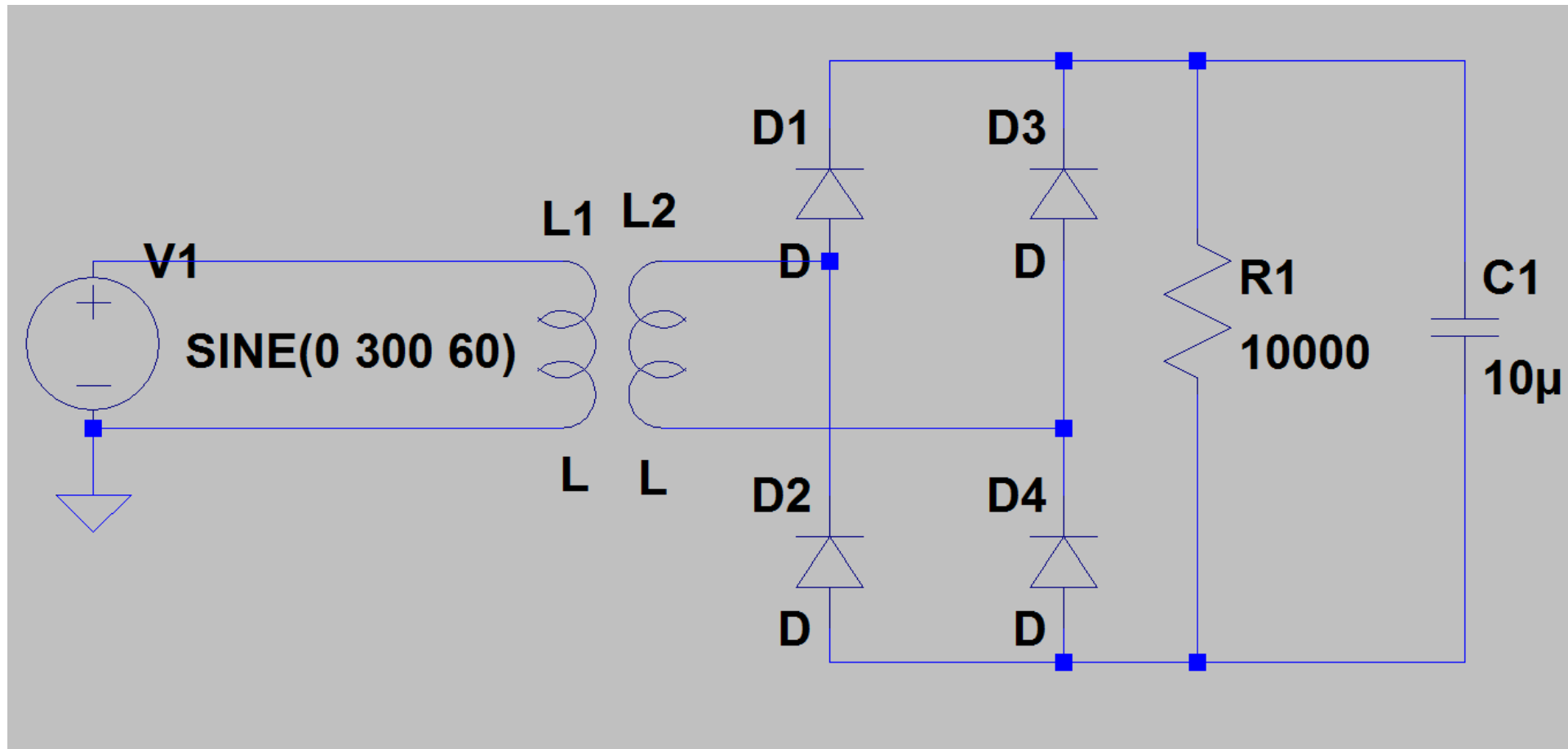

## Grounding

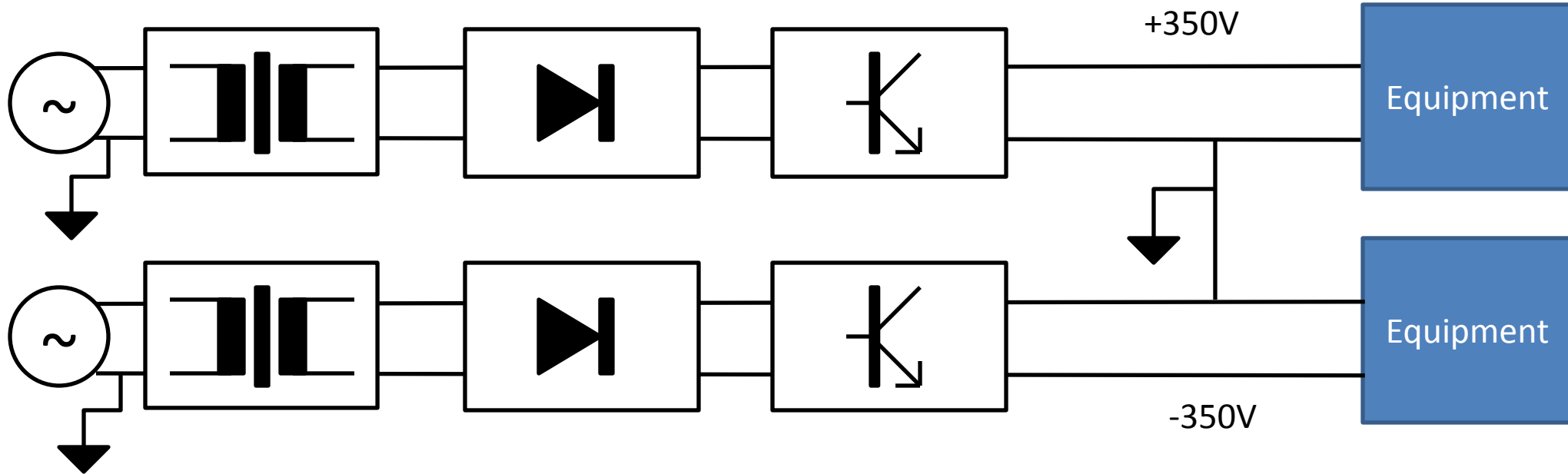

## Grounding

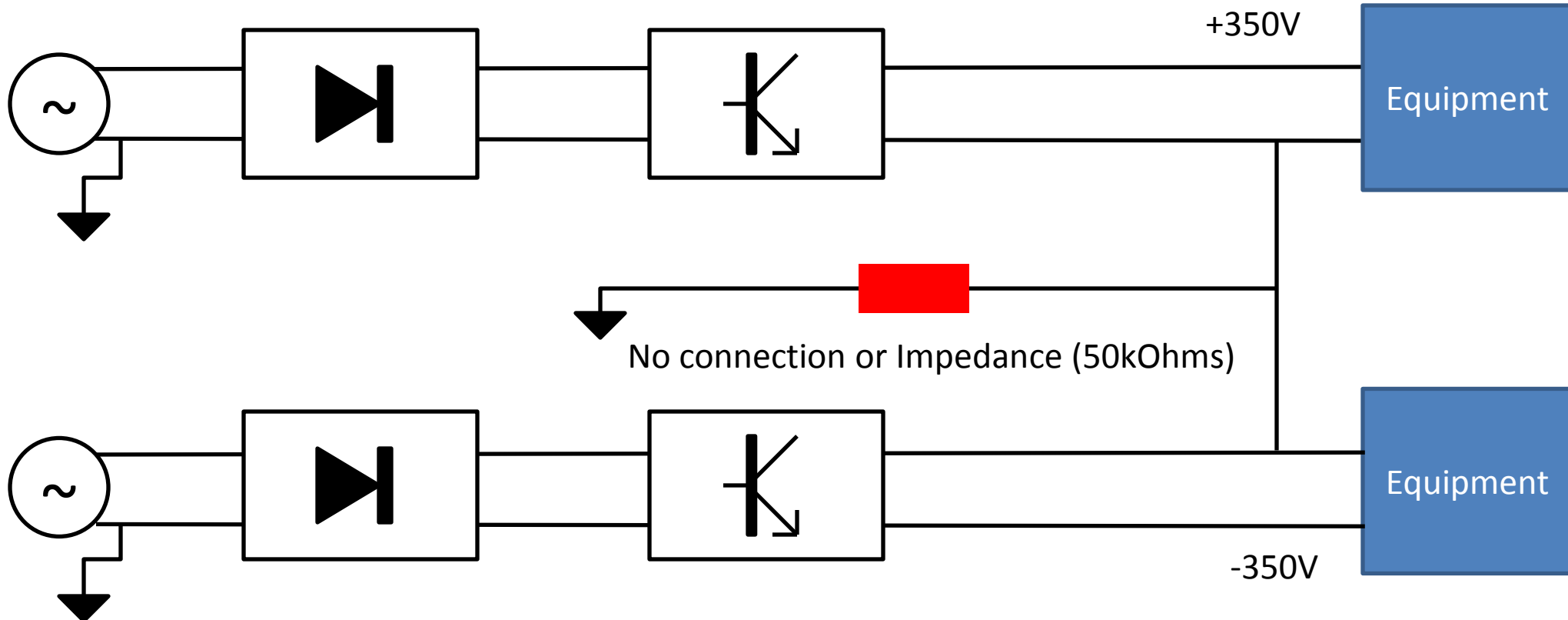

# Grounding

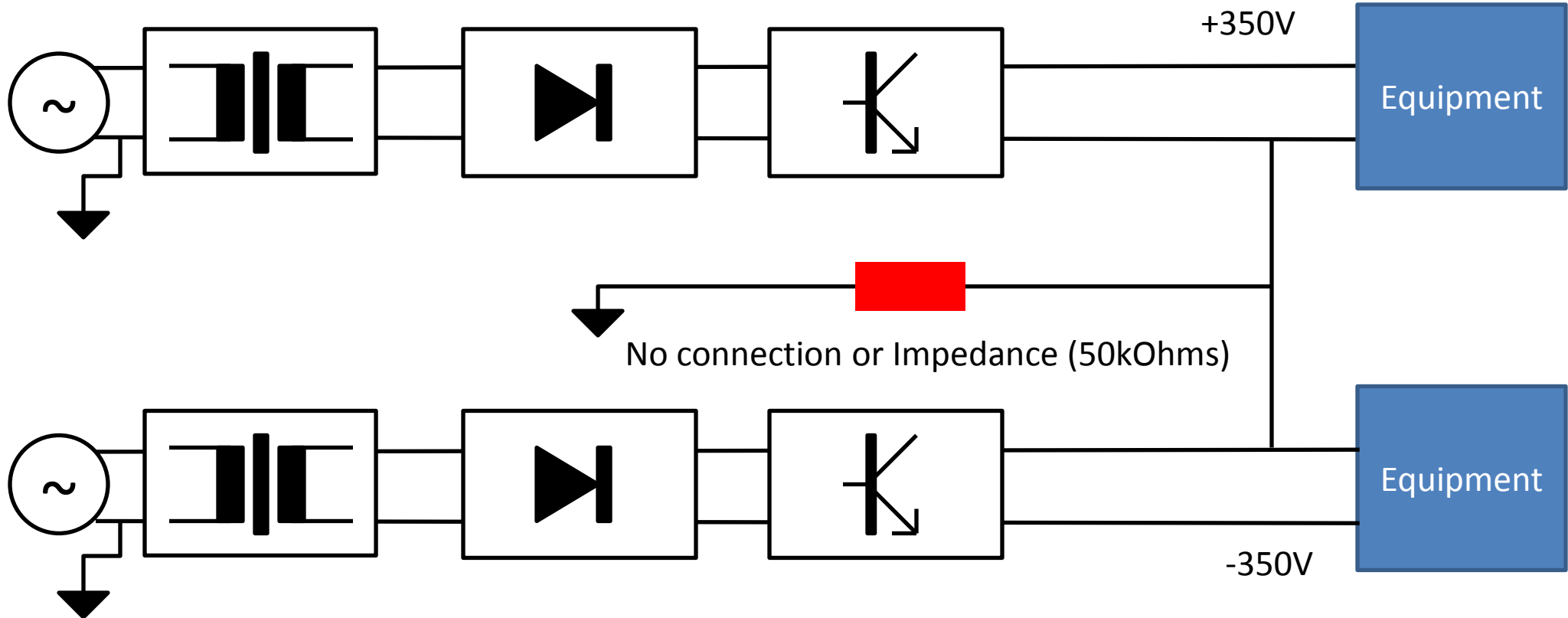



## AC/DC Converter/inverter technology about AC/DC separation

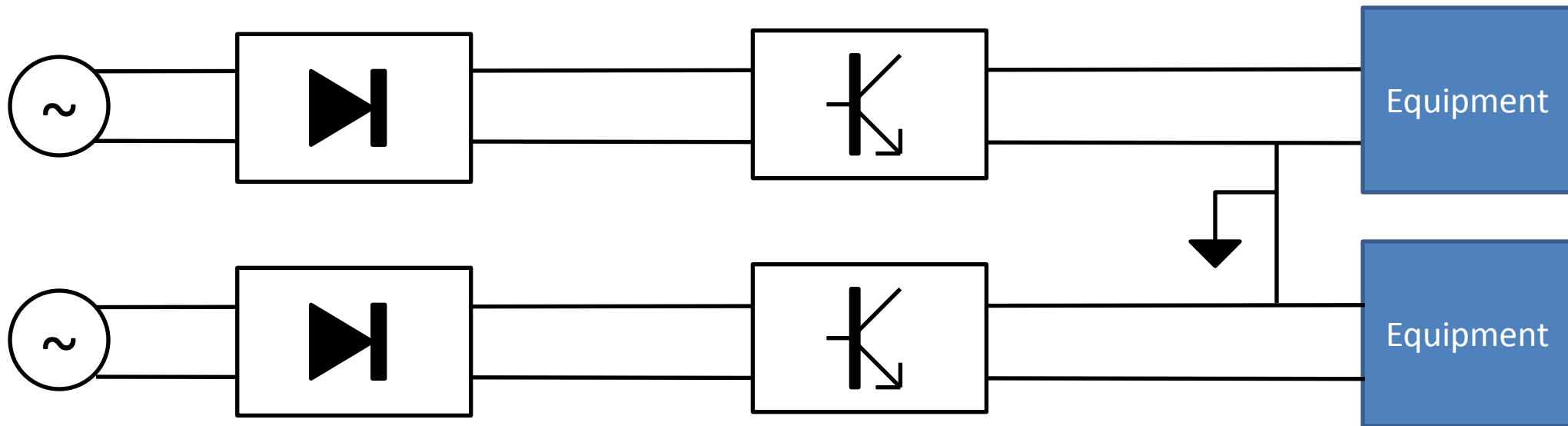

## DC voltage to ground

- Ungrounded non isolated
- Ungrounded isolated

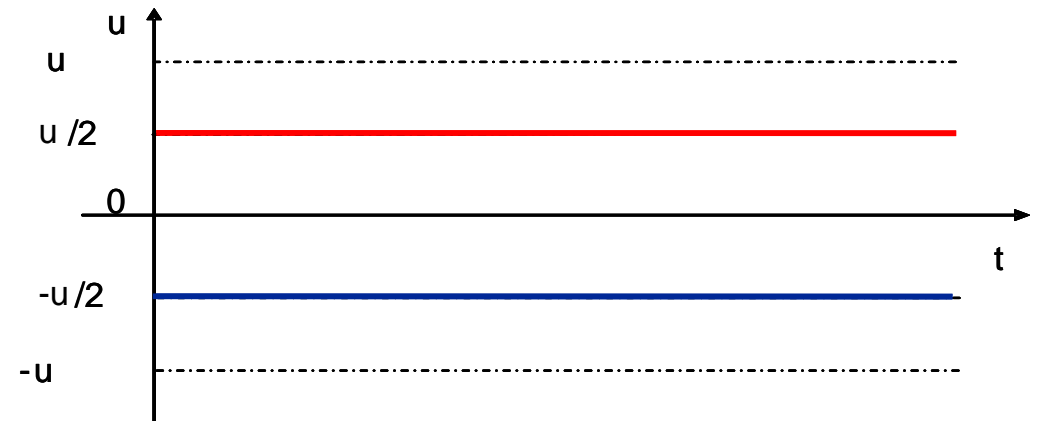
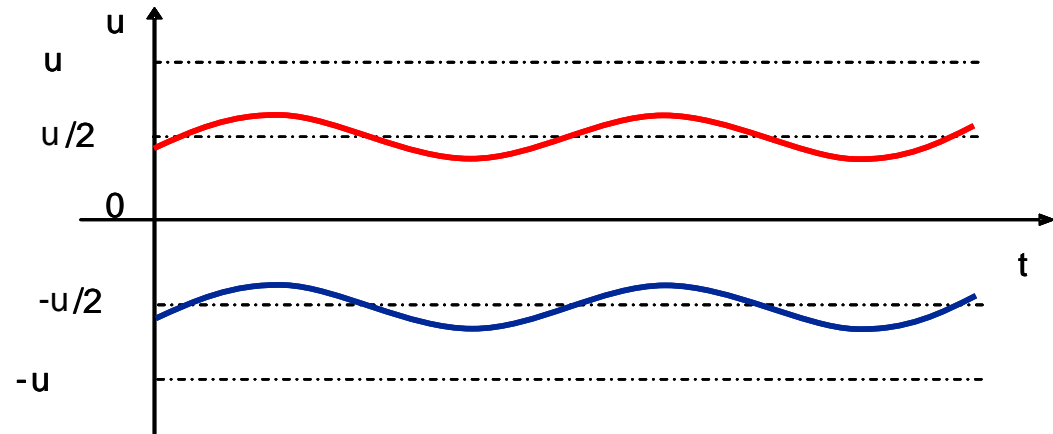

## DC voltage to ground

- “Fake” grounding

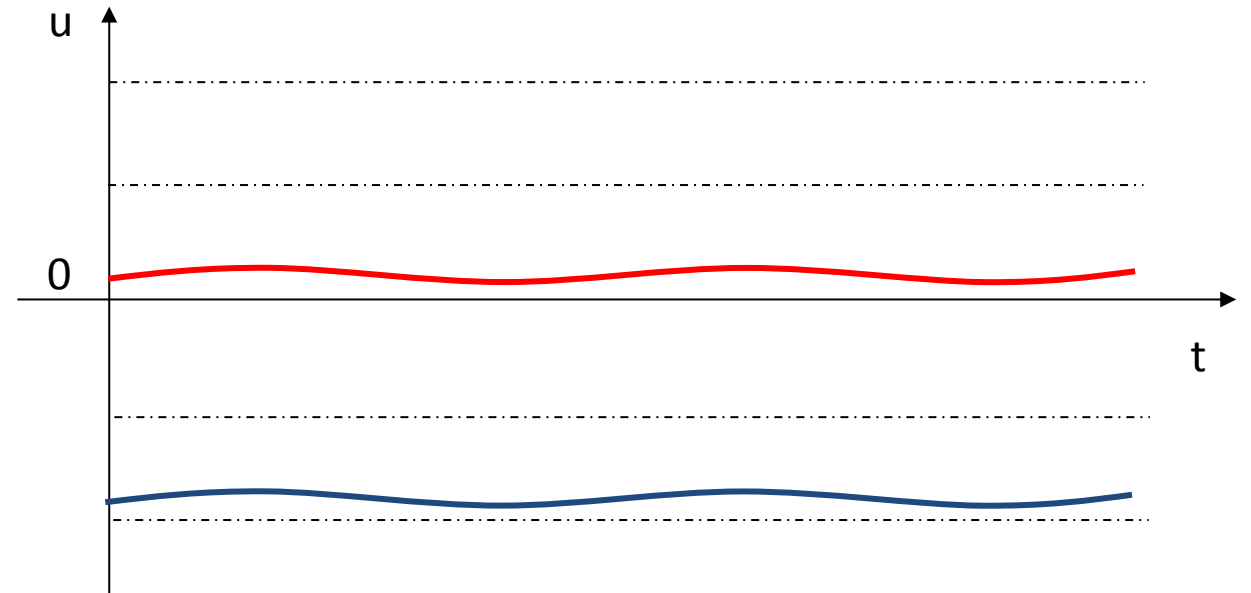

## DC voltage to ground

- Grounded Positive
  
- Grounded Negative

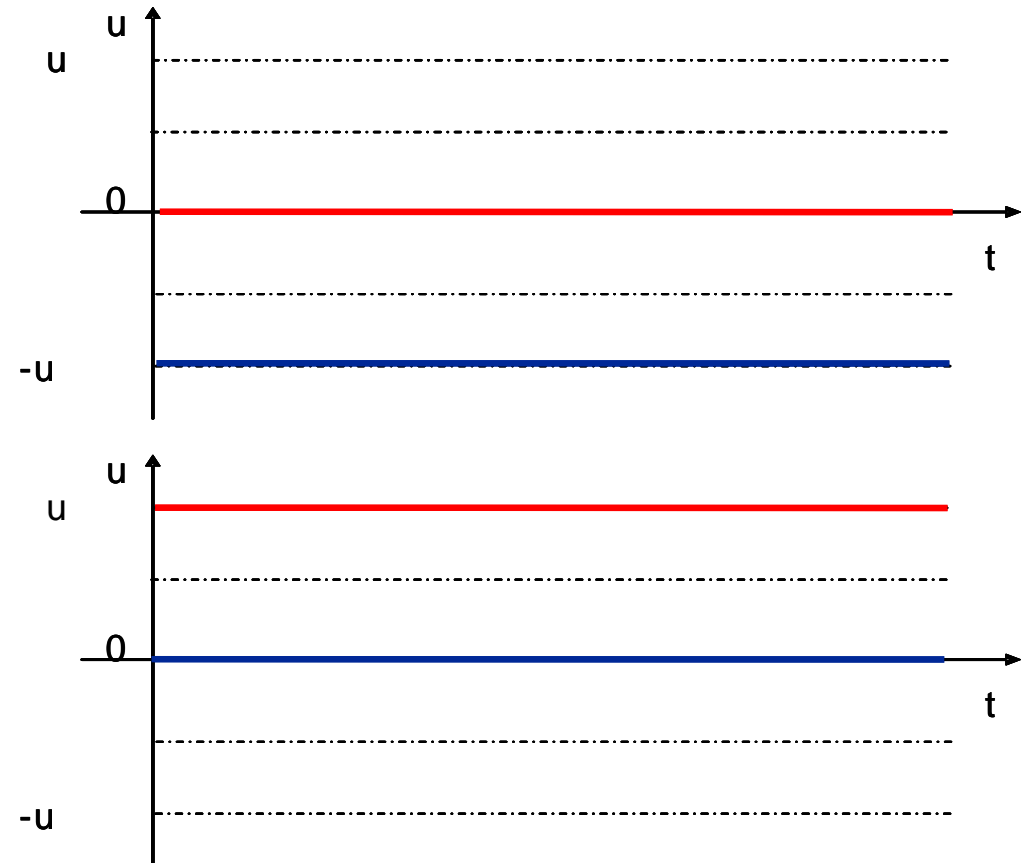

## DC voltage to ground

- Bipolar grounded
- Bipolar ungrounded

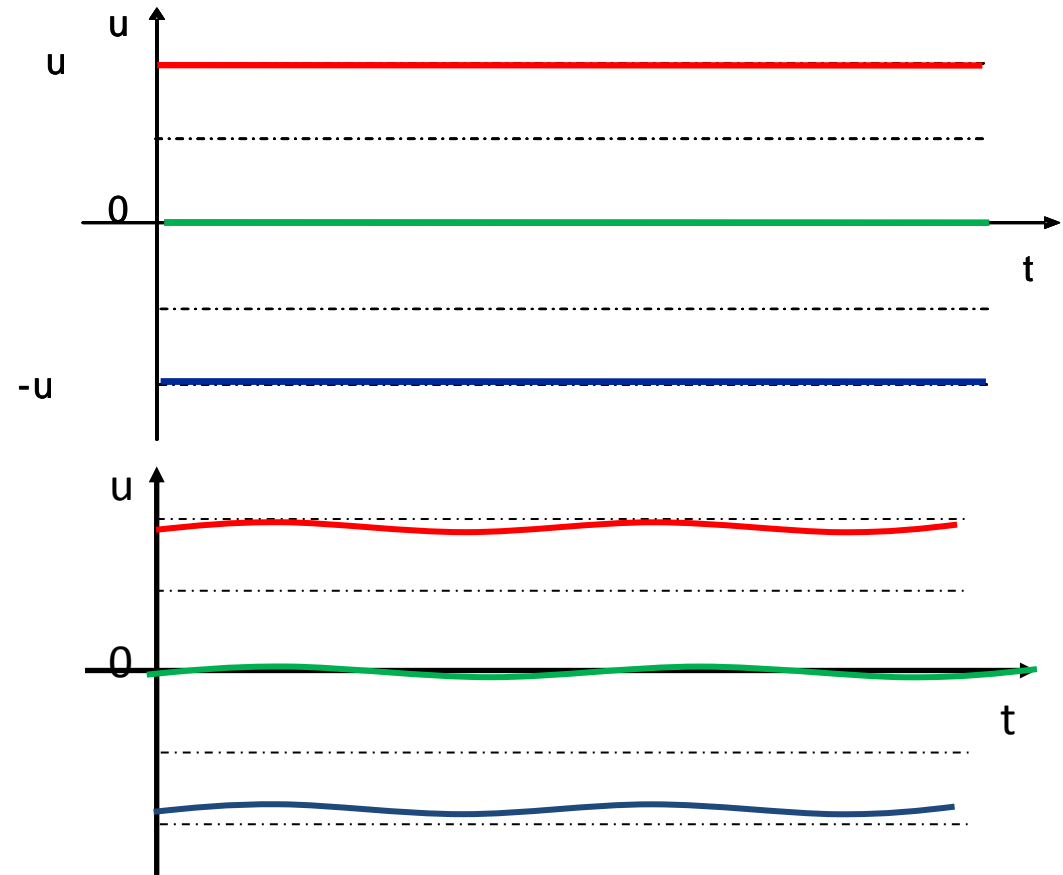

## Is this DC?

- Pulsed power supply

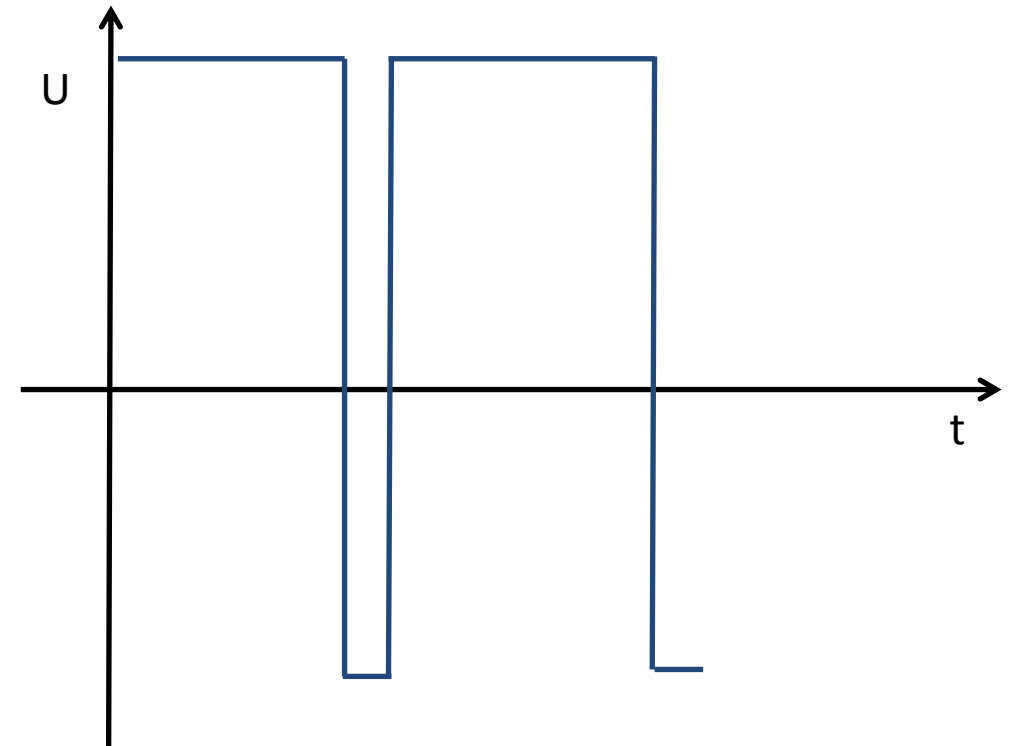
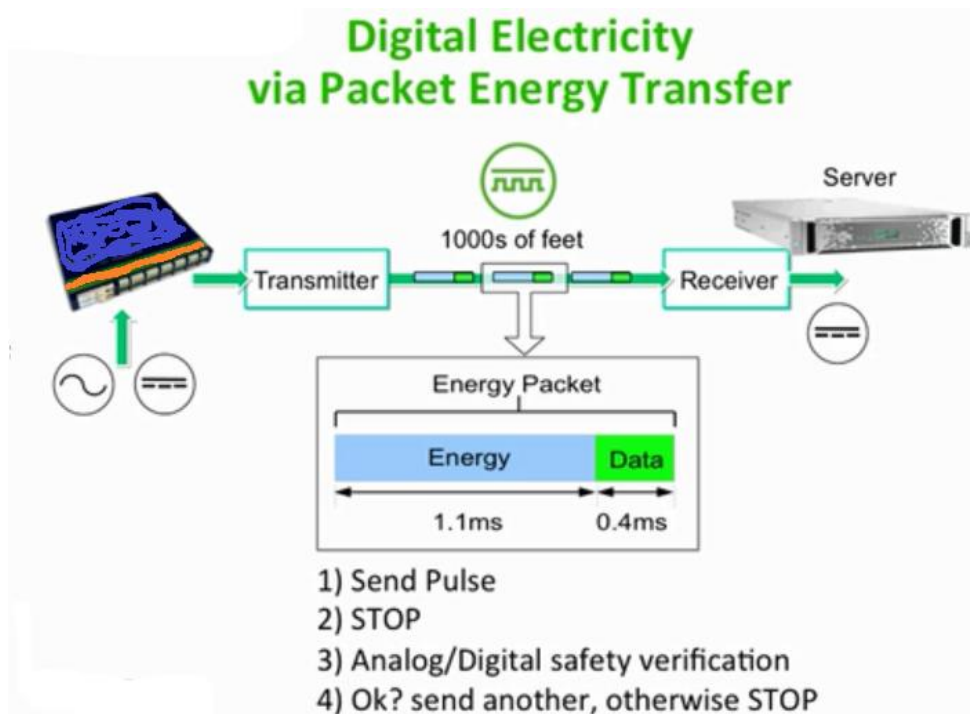

## EMI filter

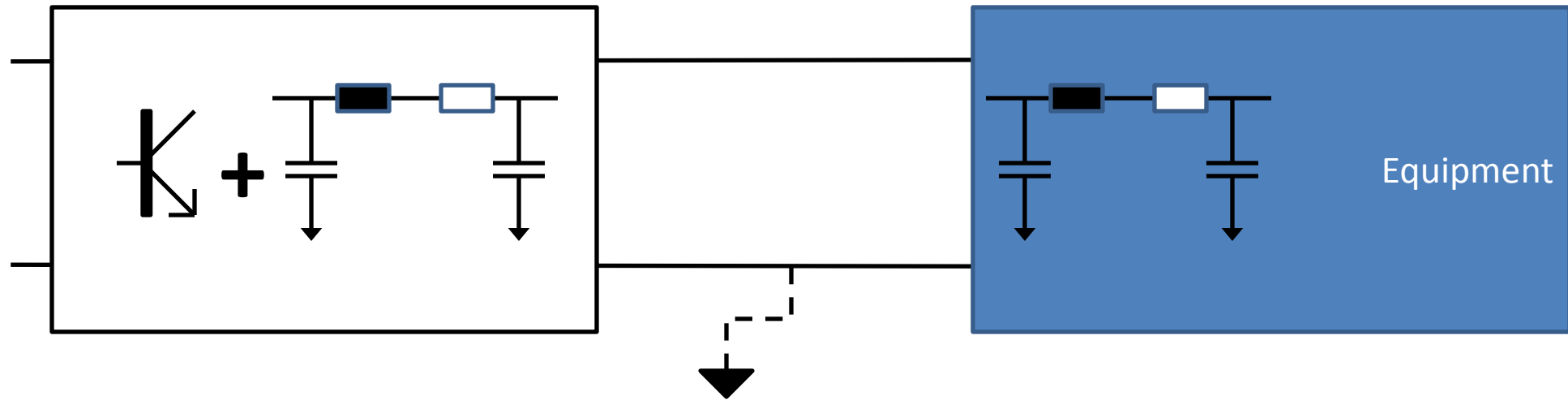

## DC equipment design: filtering and Protection diode

- Between positive and negative
- To ground

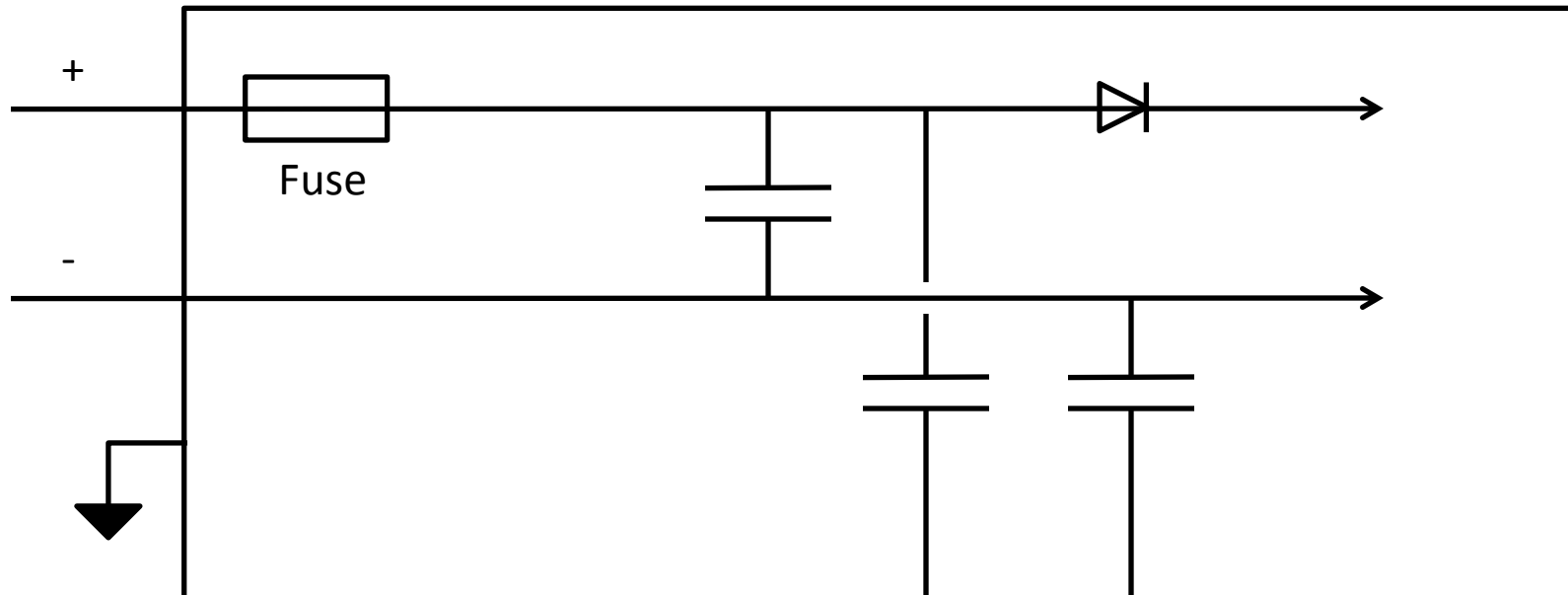



## DC power system networks sum up...

- Voltage 48V, 350V, 380V, 450V, 750V ...
- Unipolar Grounded
- Unipolar ungrounded
- Bipolar grounded
- Bipolar ungrounded
- EMI Filter
- ...

# DC power DC fault when floating DC system

- Fault to earth

Source: INTELEC, Broadbeach, Queensland, Australia, 22-26. Oktober 2017  
Safety Considerations for the Operation of Bipolar DC-Grids

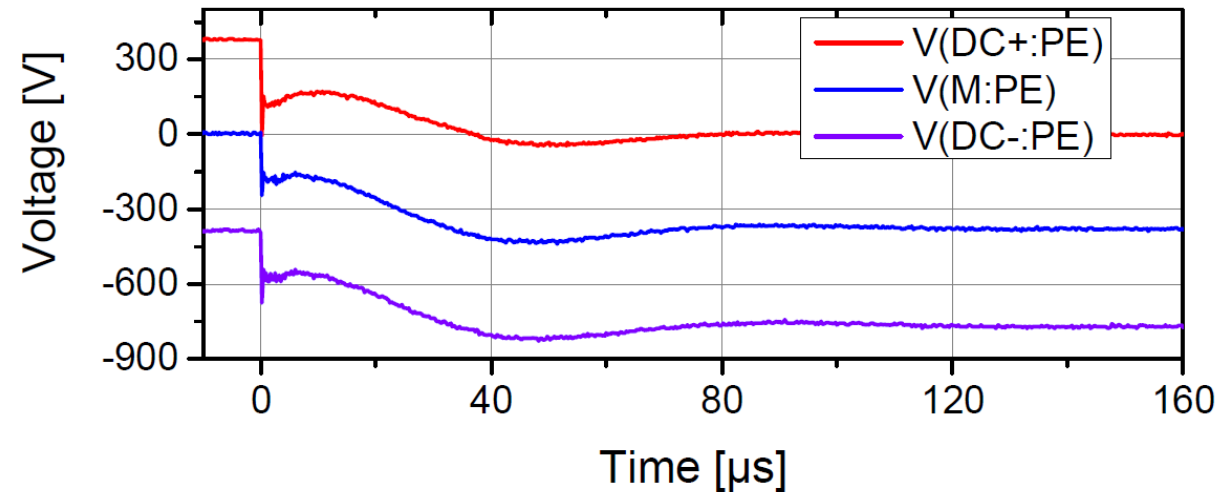
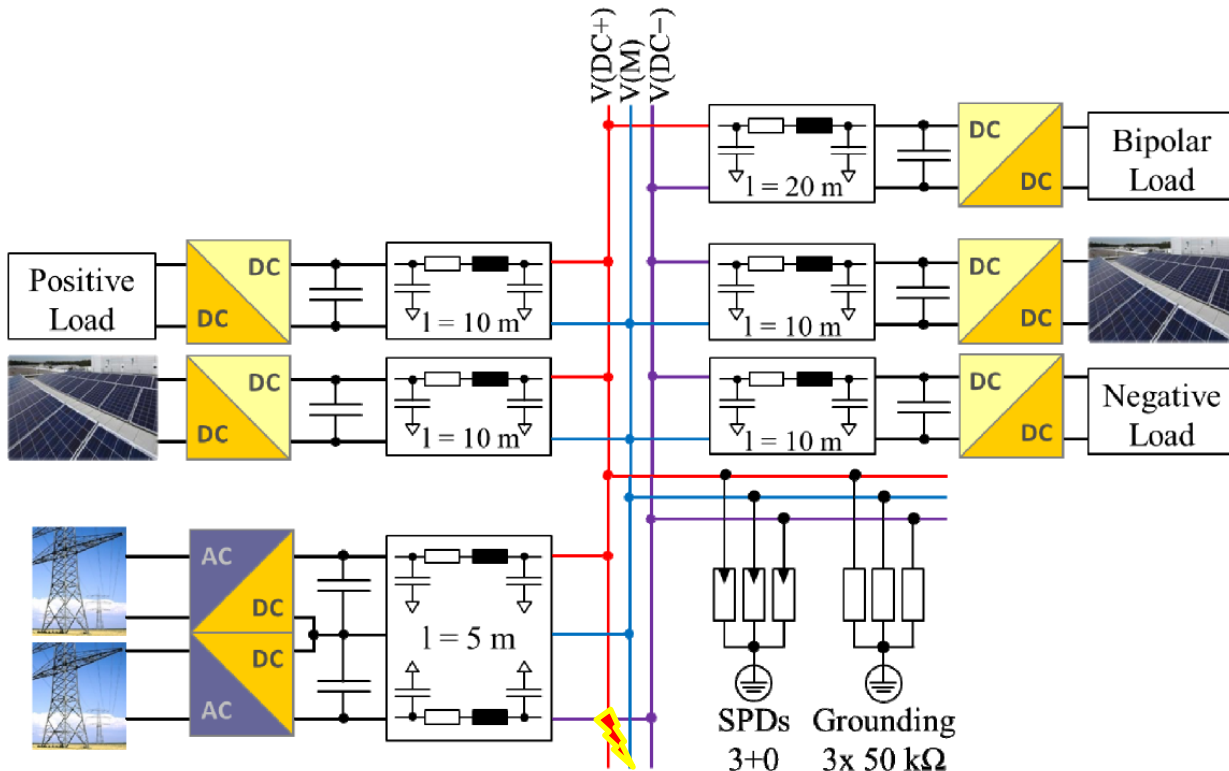

# DC power DC fault when floating DC system

- Loss of neutral

Source: INTELEC, Broadbeach, Queensland, Australia, 22-26. Oktober 2017  
Safety Considerations for the Operation of Bipolar DC-Grids

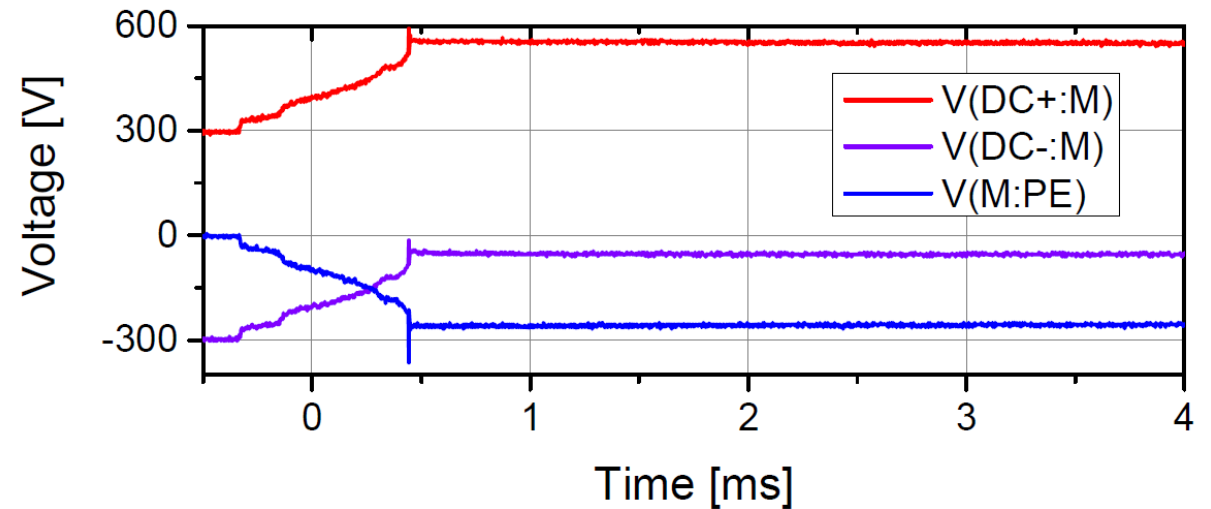
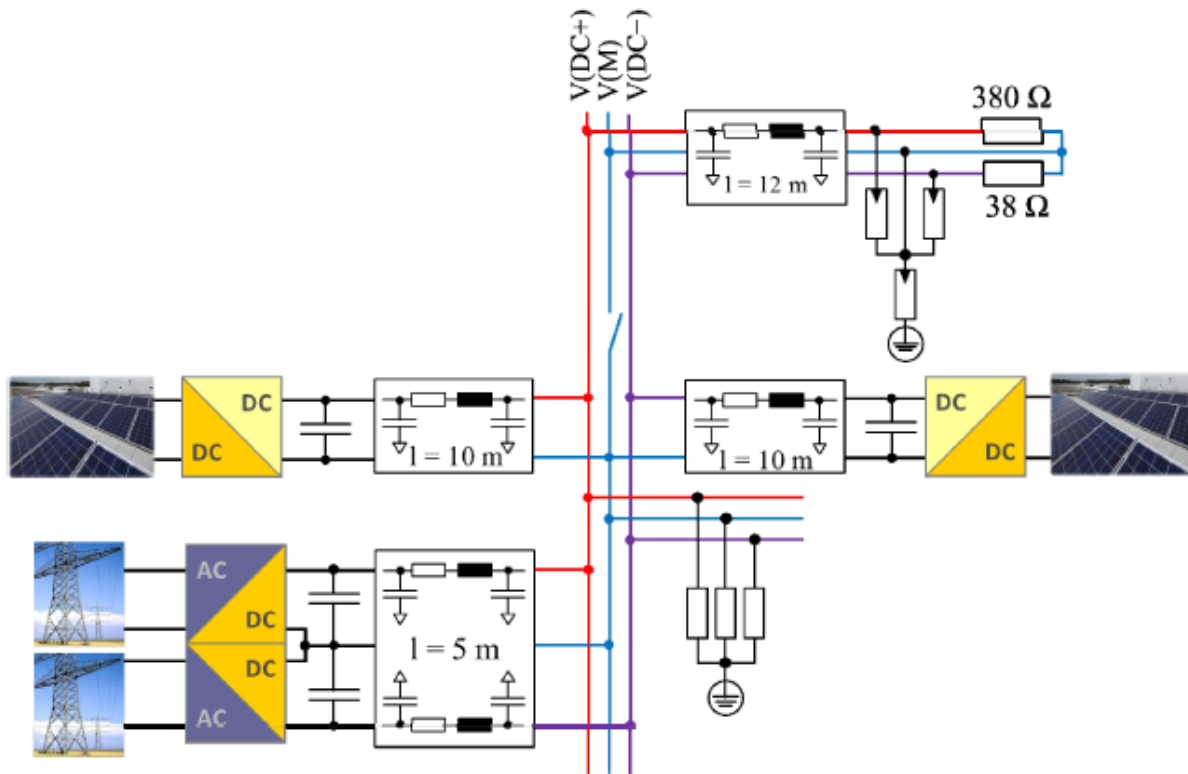

## Other DC TOV possible sources

- Power crossing
  - With other DC power system
  - With AC power system

# SPD technology

- Varistors

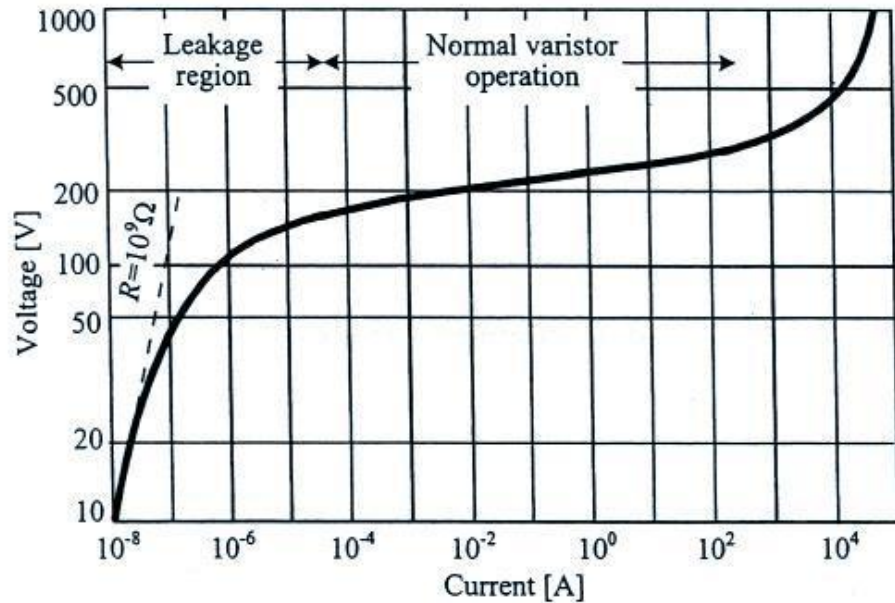
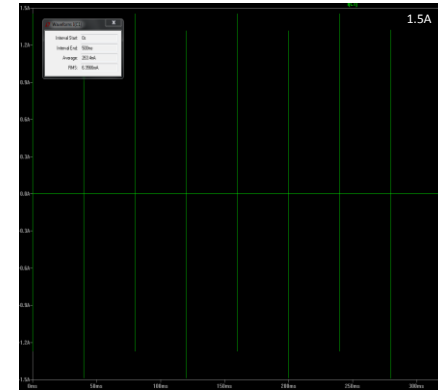
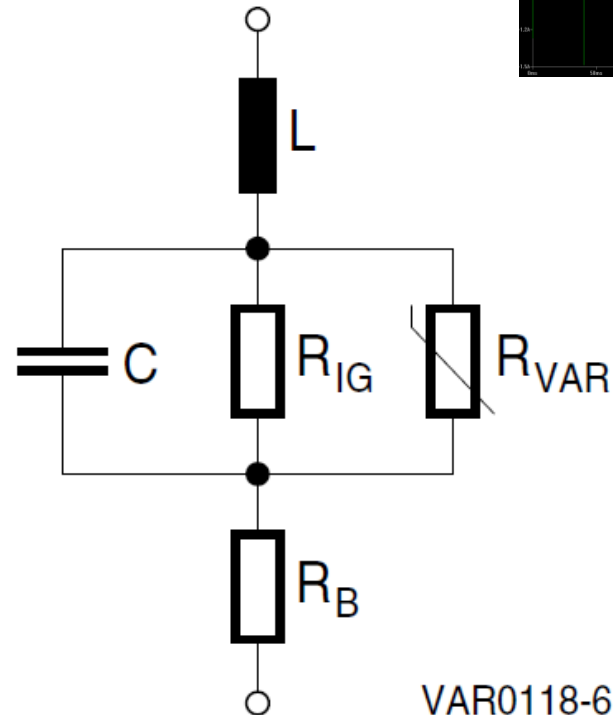
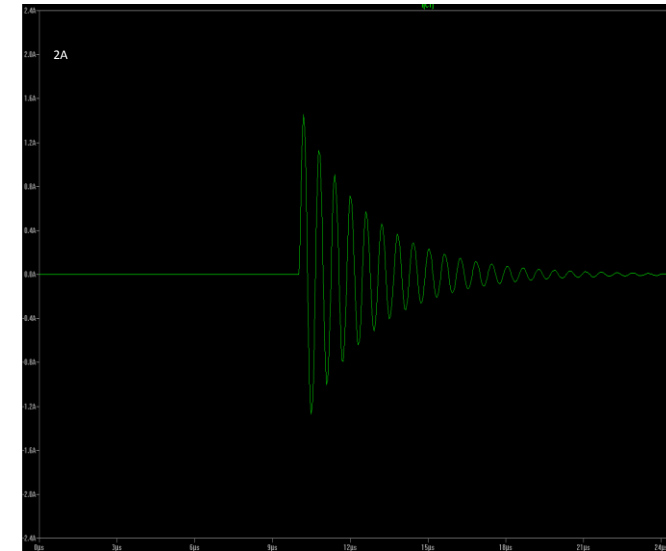

Fig. 6.4 Voltage vs. current characteristic for a metal-oxide varistor (MOV) used on a 110 volt household circuit. Adapted from Littelfuse arrester catalogue AN 9767.1.

Leakage...



C ~ few nF



## SPD technology

- GDTs

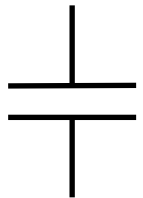
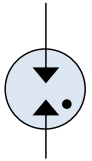

Few pF

- Spark Gap (triggered)

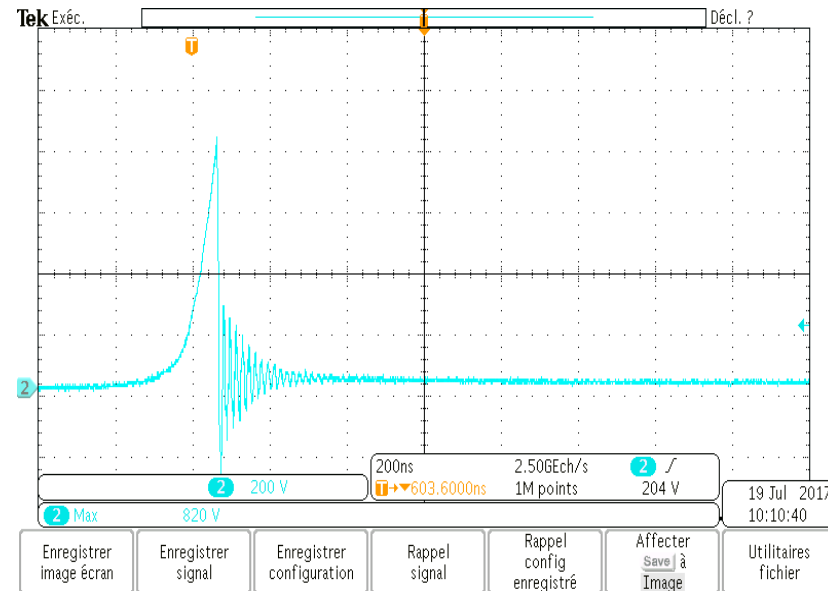

Quenching... Few 100A DC

Quenching... 100A AC... 1A DC...

## SPD technology

- Association of :
  - MOV + GDT in series
  - MOV + GDT in Parallel
  - MOV + Diodes
  - MOV + GDT + Diodes
  - Etc.

# SPD assembly

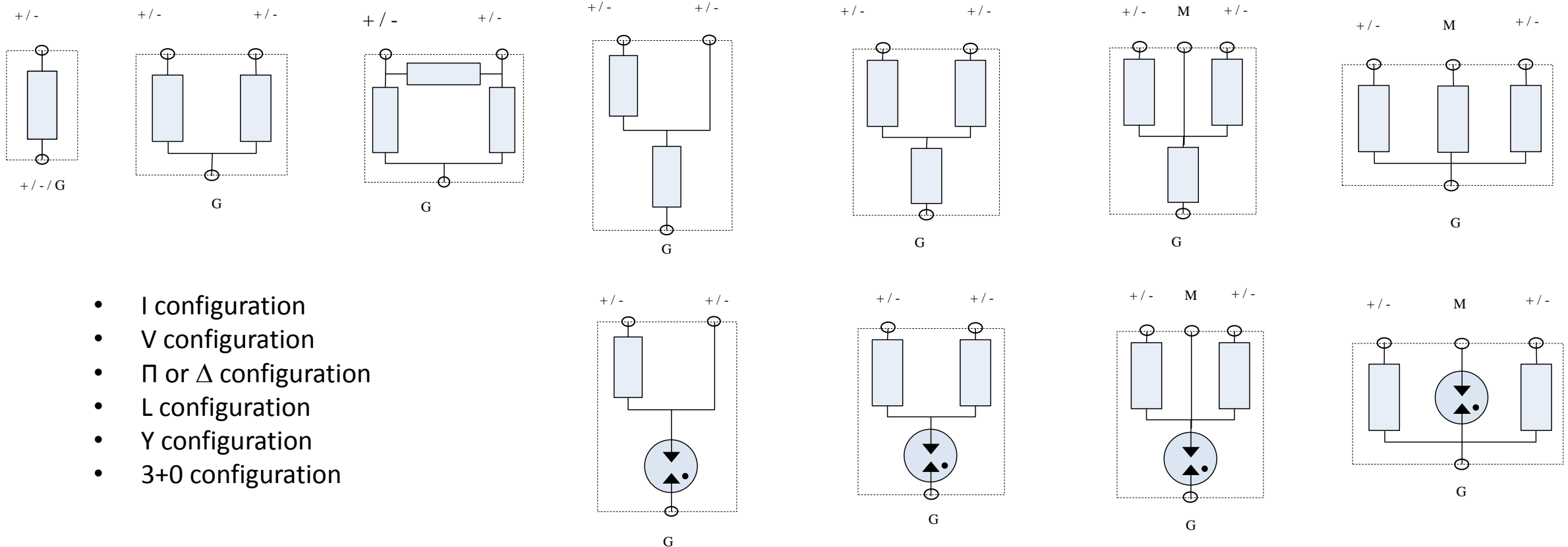

- I configuration
- V configuration
- Π or Δ configuration
- L configuration
- Y configuration
- 3+0 configuration



## EOL of an SPD

How can a SPD reach the EOL status?

- Extended number of impulses lower or equal to  $I_n$
- One or more impulse(s) exceeding the crest value of  $I_{max}$
- One or more impulse(s) with longer waveforms as 8/20 $\mu$ s caused by switching operations or partial lightning currents etc.
- Temporary Overvoltages exceeding the energy withstand of the SPD
- Ageing/degradation by environmental influences

## End of life behavior of SPDs

- Basic Rule: In case of EoL of the SPD mustn't create risk for fire protection and human being protection.
- EoL behavior
  - **Short Circuit Mode**
  - Open Circuit Mode
  - 2 States Modes

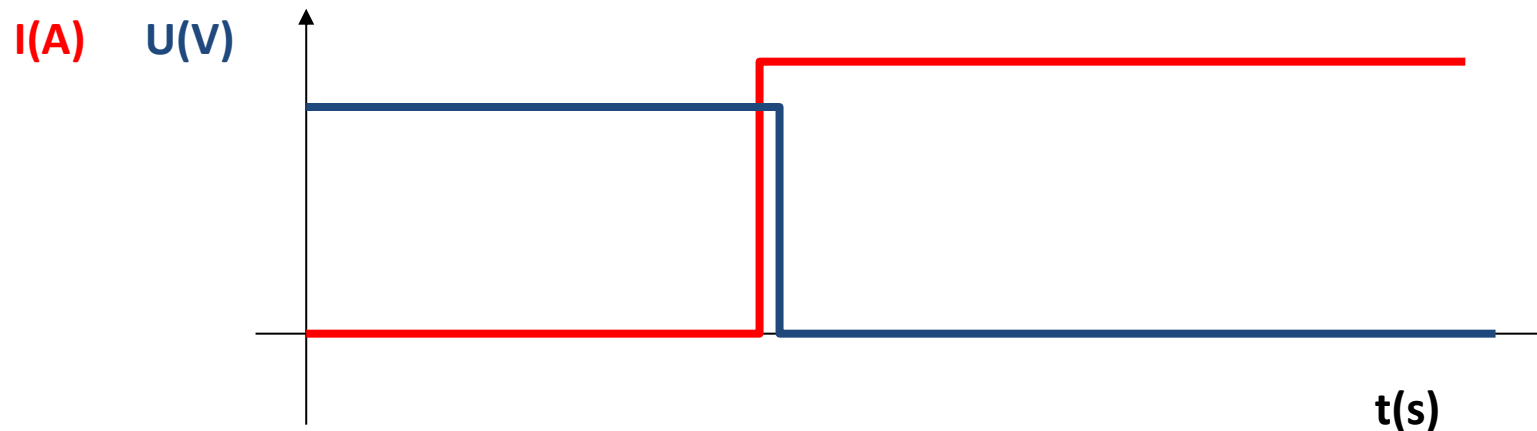

## End of life behavior of SPDs

- Basic Rule: In case of EoL of the SPD mustn't create risk for fire protection and human being protection.
- EoL behavior
  - Short Circuit Mode
  - **Open Circuit Mode**
  - 2 States Modes

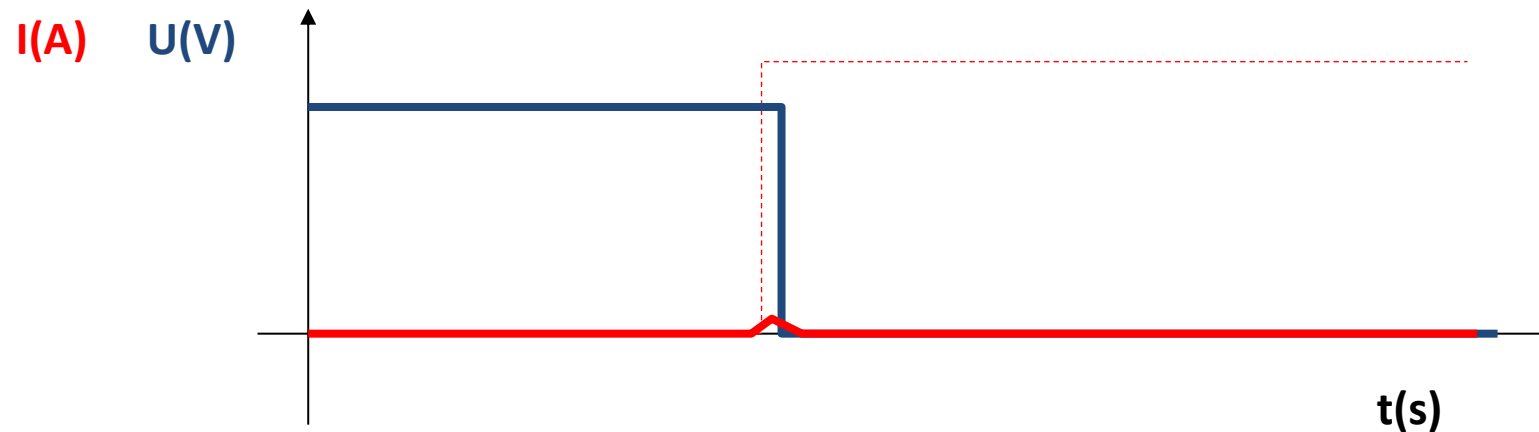

## End of life behavior of SPDs

- Basic Rule: In case of EoL of the SPD mustn't create risk for fire protection and human being protection.
- EoL behavior
  - Short Circuit Mode
  - Open Circuit Mode
  - **2 States Modes**

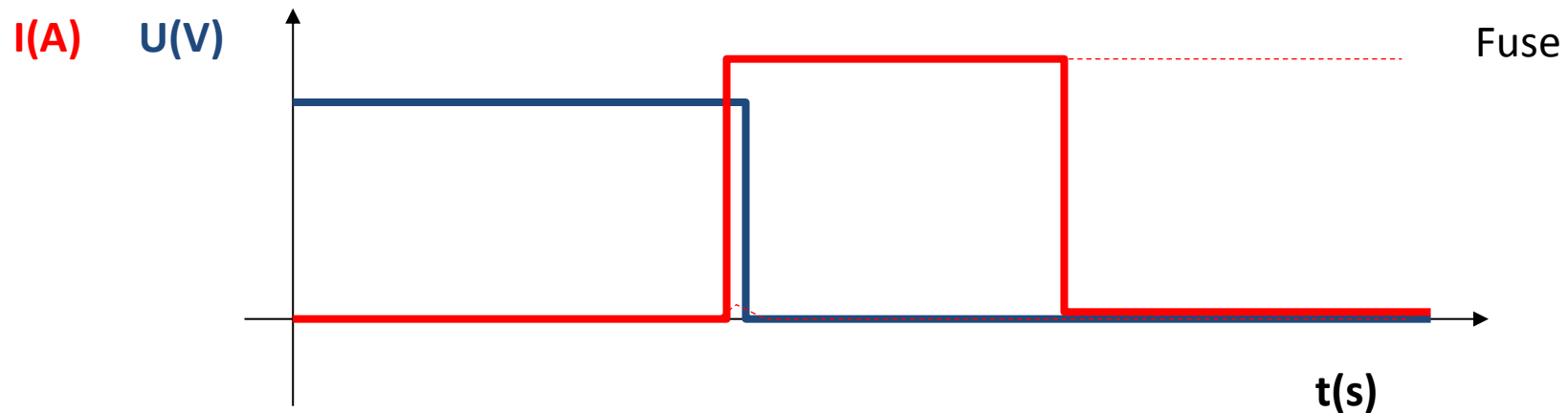

## End of life behavior of SPDs

- Basic Rule: In case of EoL of the SPD mustn't create risk for fire protection and human being protection.
- EoL behavior
  - Short Circuit Mode
  - Open Circuit Mode
  - 2 States Modes

**4<sup>th</sup>**

**SPD = impedance of few Ohms**

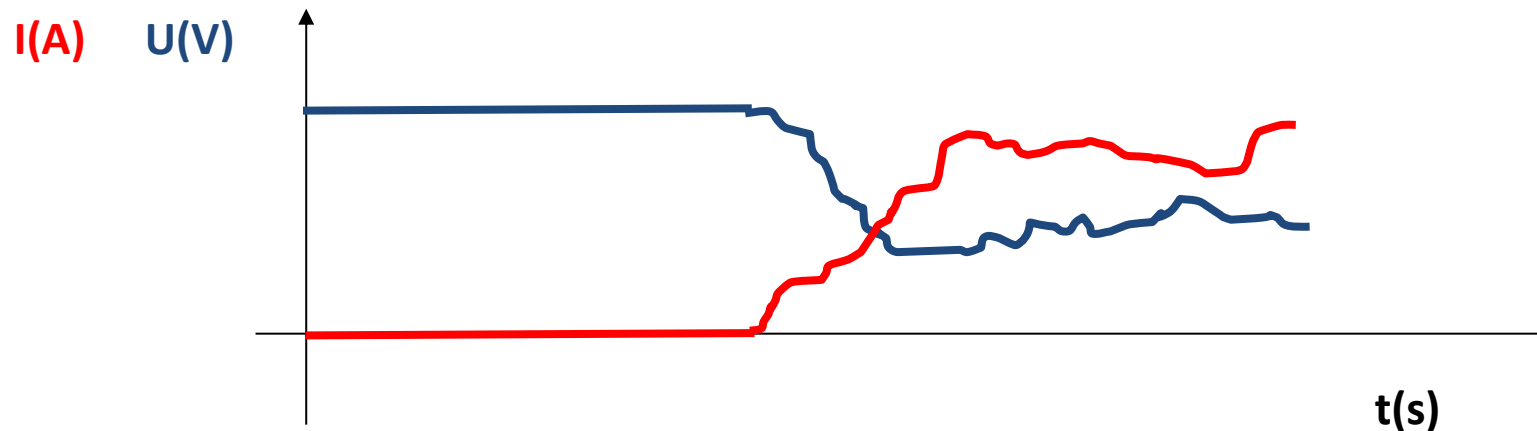

## Disconnection means (can be inside or outside the SPD)

- SCC disconnect

- Thermal disconnect

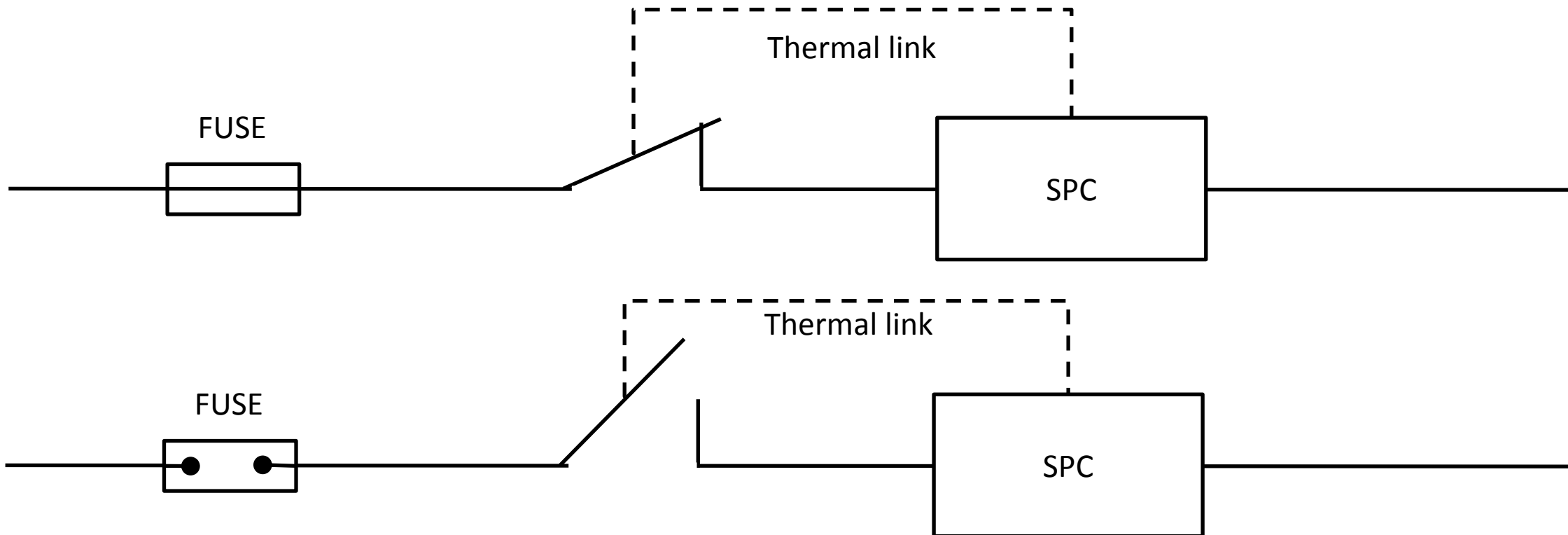

## EOL of an SPD stressed by number of impulses lower or equal to $I_n$

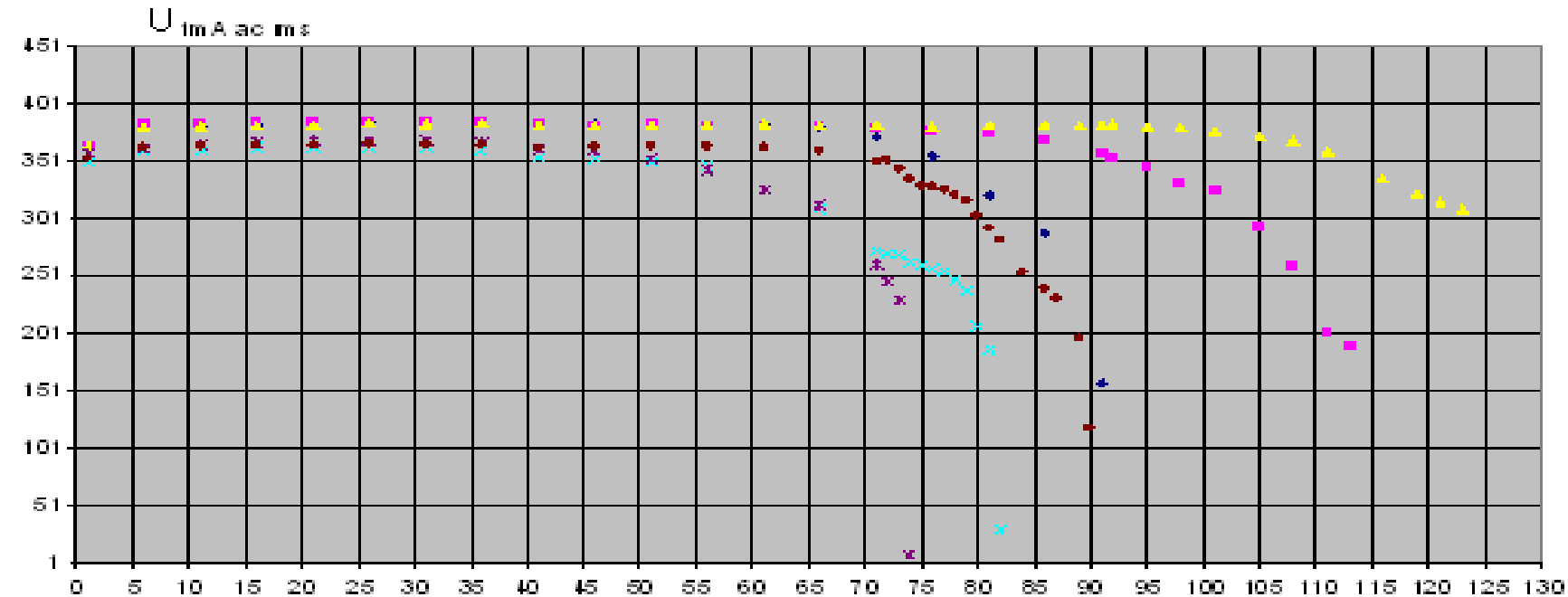

34x34 square MOV



Number of shot

A SPD subjected to a excessive number of impulses exceeding the operating duty test conditions changes its V/I-characteristic by far

- Changes of V/I-characteristic may occur gradually or suddenly
- Power follow current may occure immediately or slowly

# EOL of an SPD stressed by number of impulses lower or equal to $I_n$

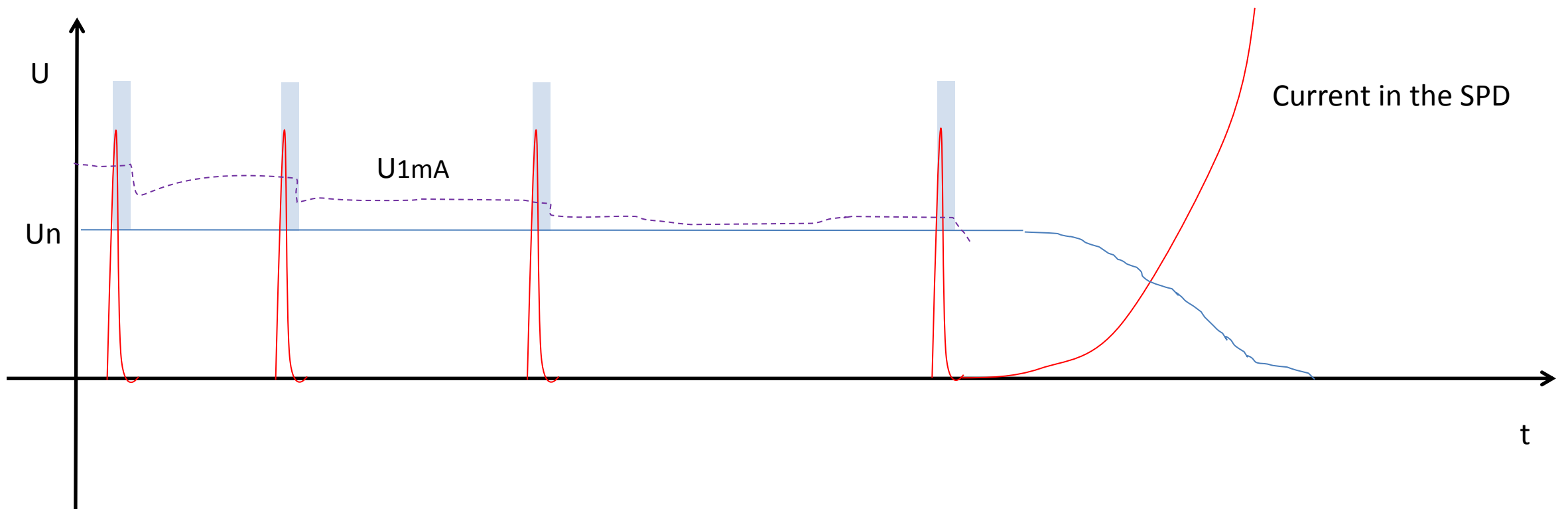



# Is EOL identical for all SPD even if same design?

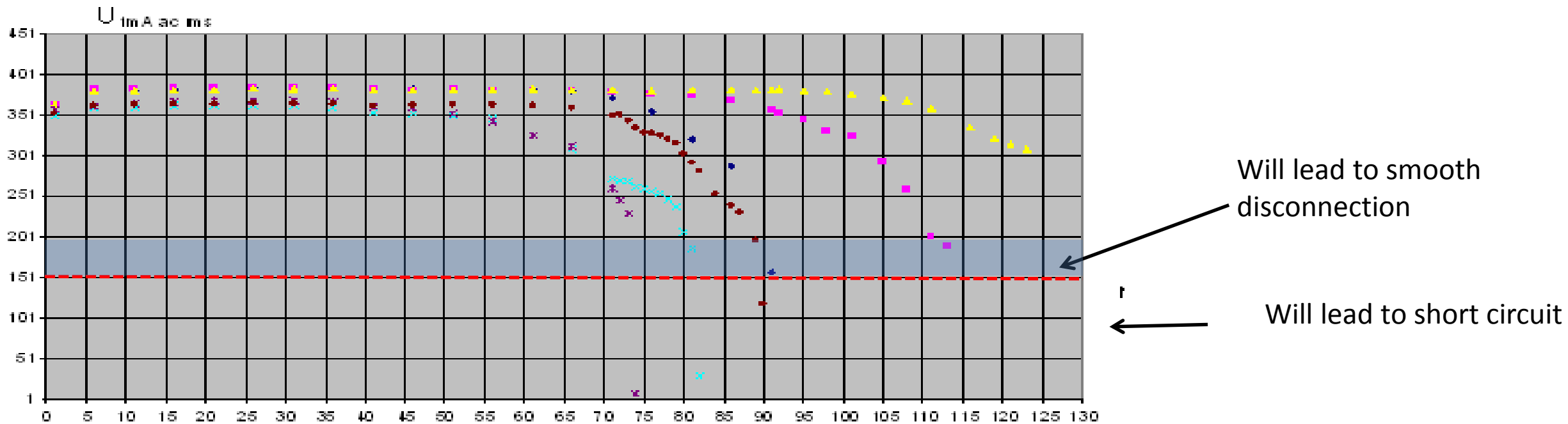

## Reminder about DC quenching

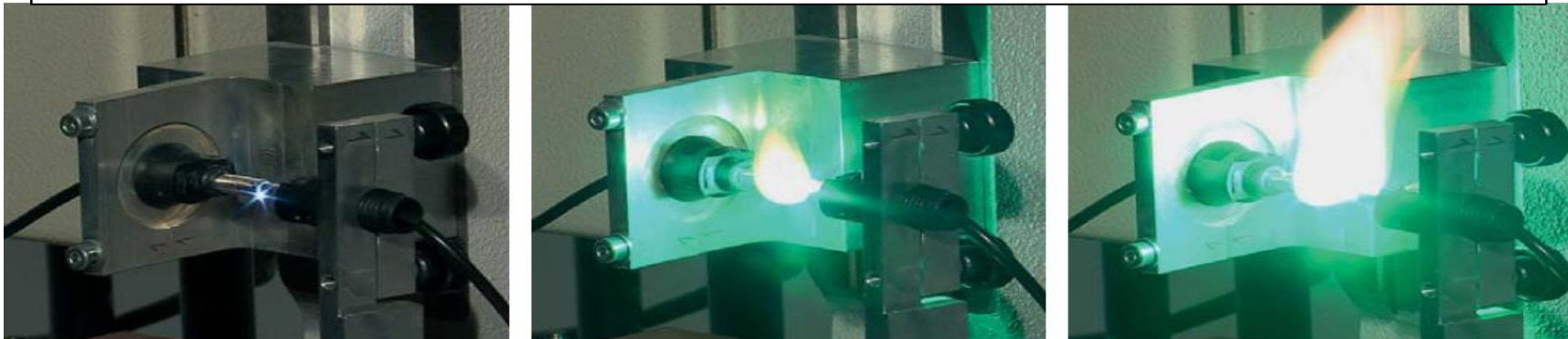
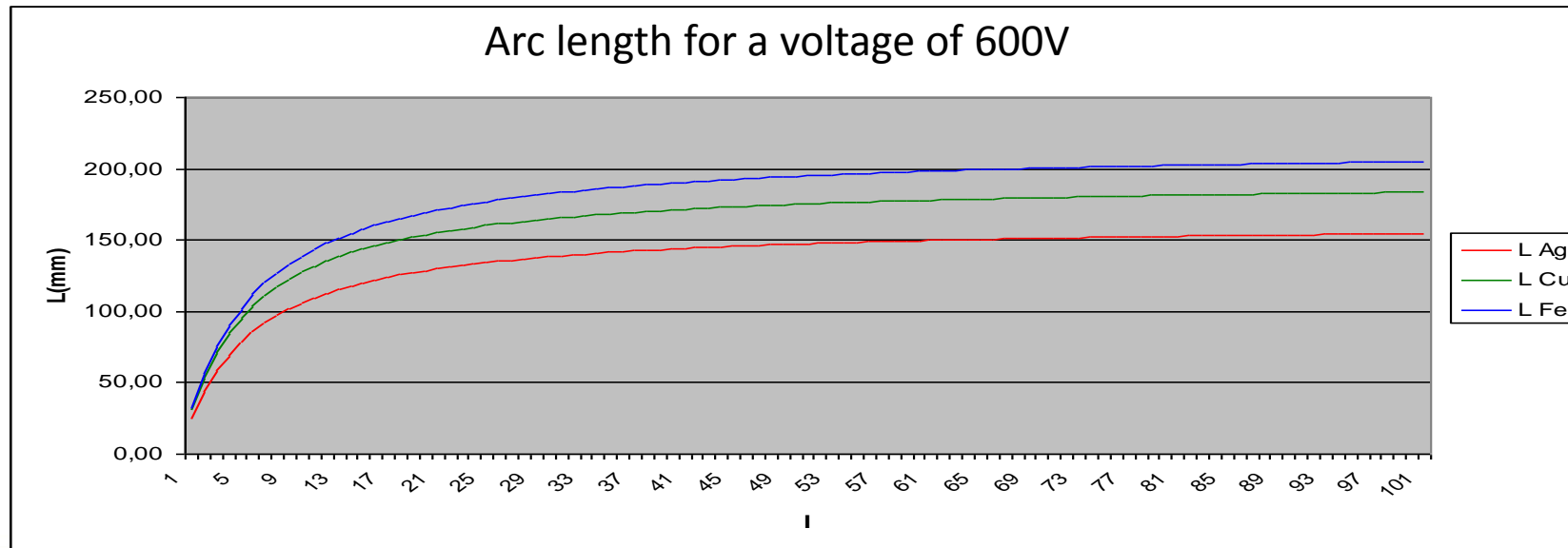

## DC and SPD's testing from standards

- UL 1449
  - of 2.5A, 10A, 100 A, 500 A, 1000 A and at the SCCR
  - lower voltage rated MOV(s) with  $V_n$  @1ma equal to 60 – 80% of the  $V_{dcmcov}$
  - *one or more MOVs may be shorted to achieve the requirements of  $V_n$  of the mode to be equal to 60 - 80% of the  $V_{dcmcov}$*
  - *a test voltage that is equal to or greater than the measured  $V_n$ @1ma of the MOV divided by 0.80*

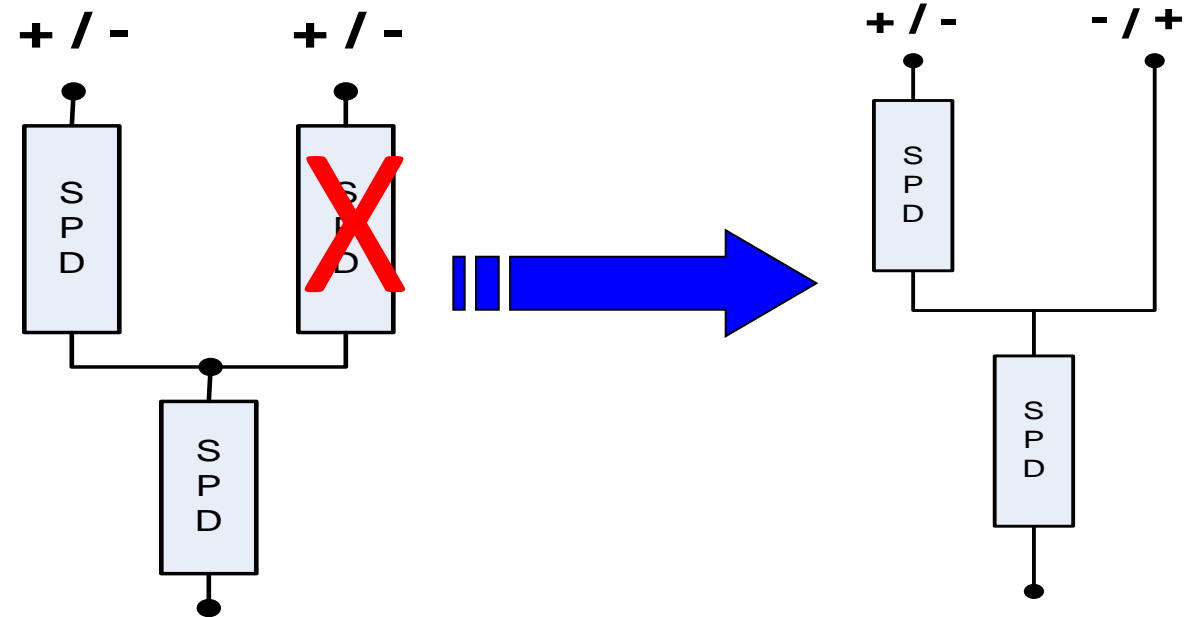

## DC and SPD's testing from standards

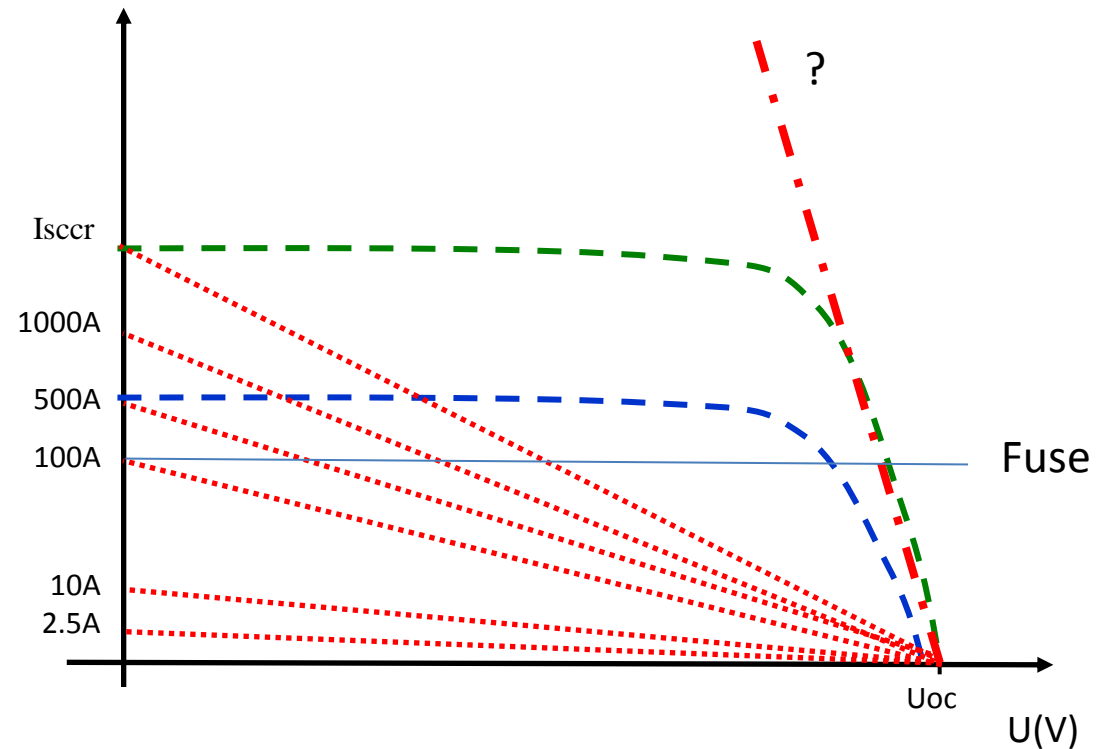
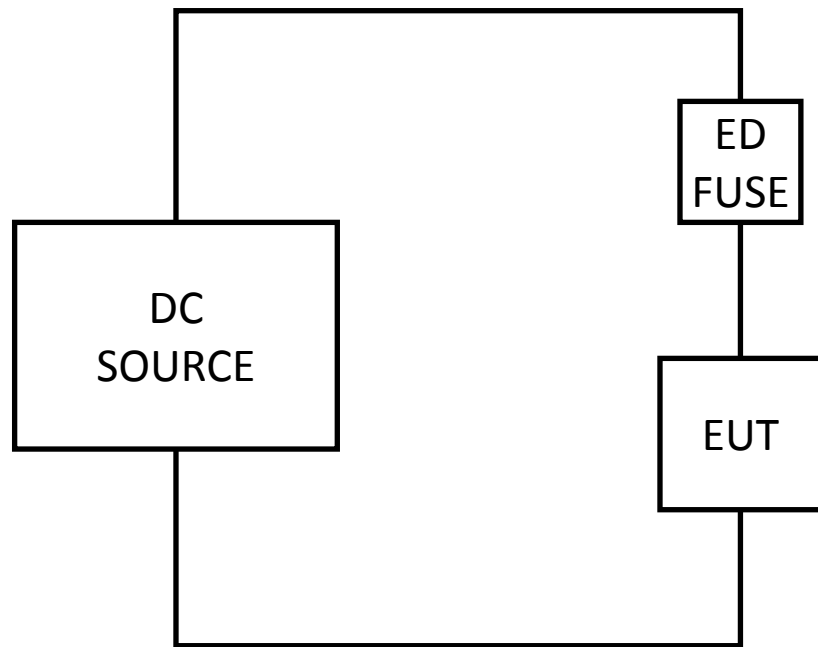

## DC and SPD's testing from standards

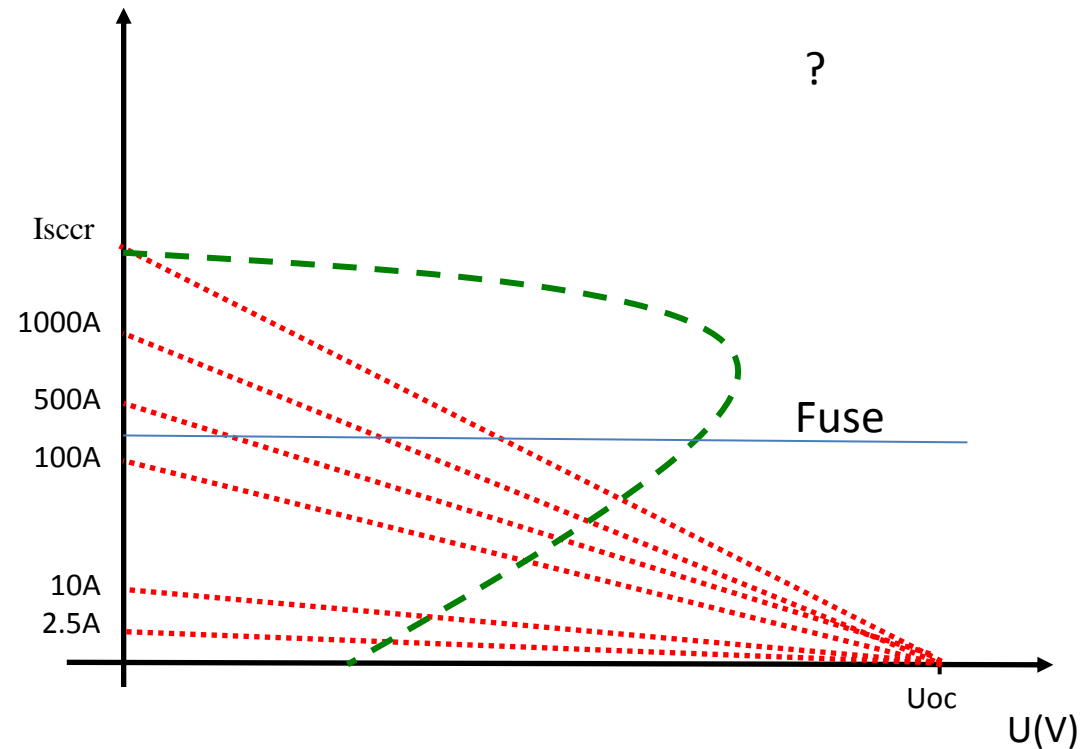
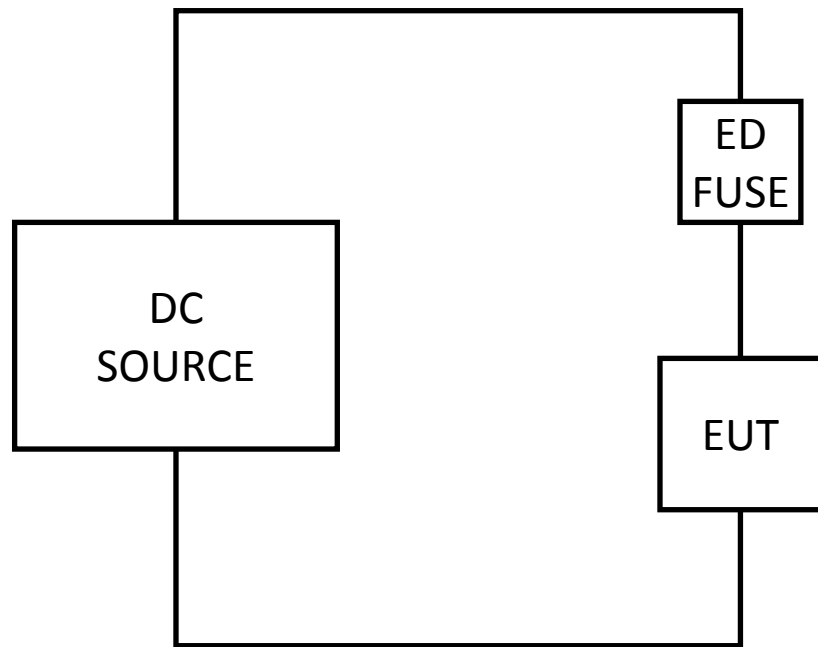

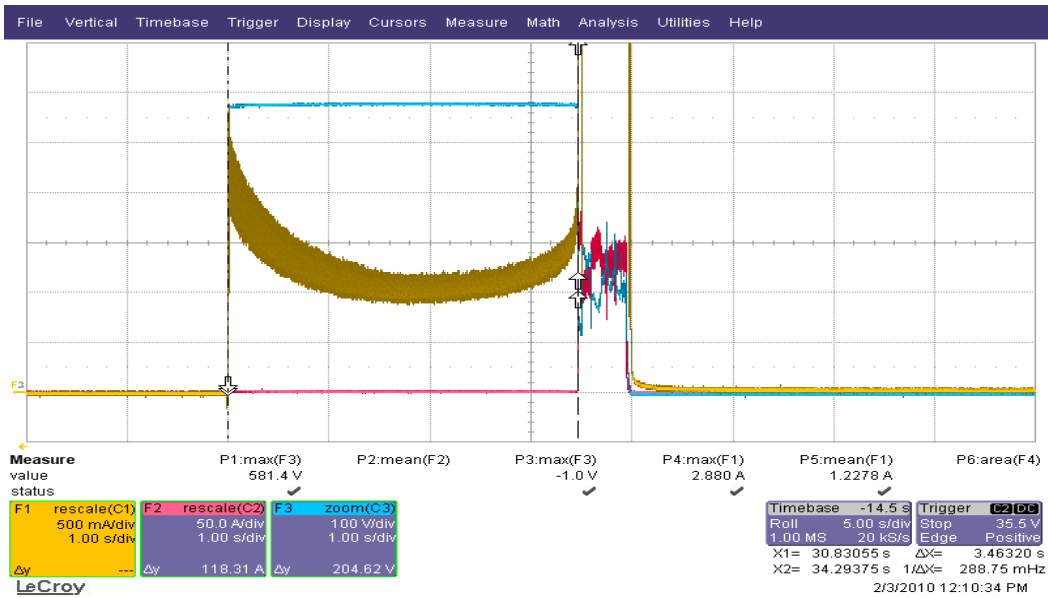

I max: 2.88A  
 I mean: 1.22  
 Time to fail: 3.5s

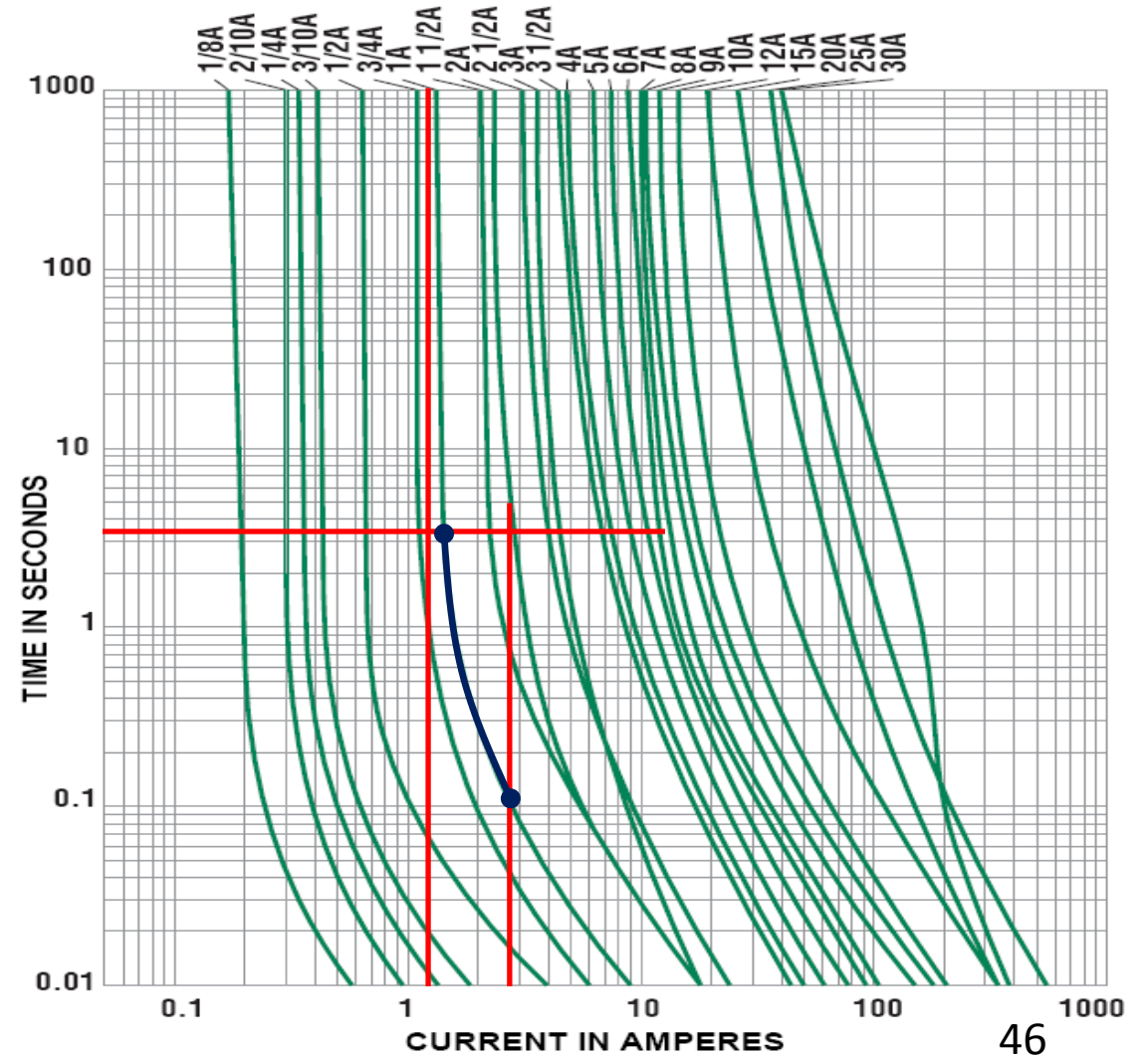

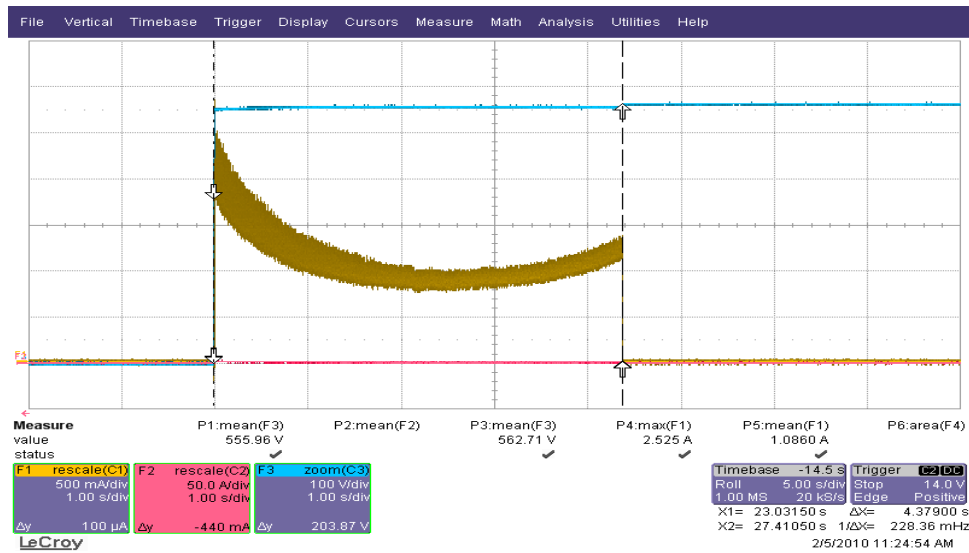

I max: 2.52A  
I mean: 1.09A  
Time to disconnect: 4.4s

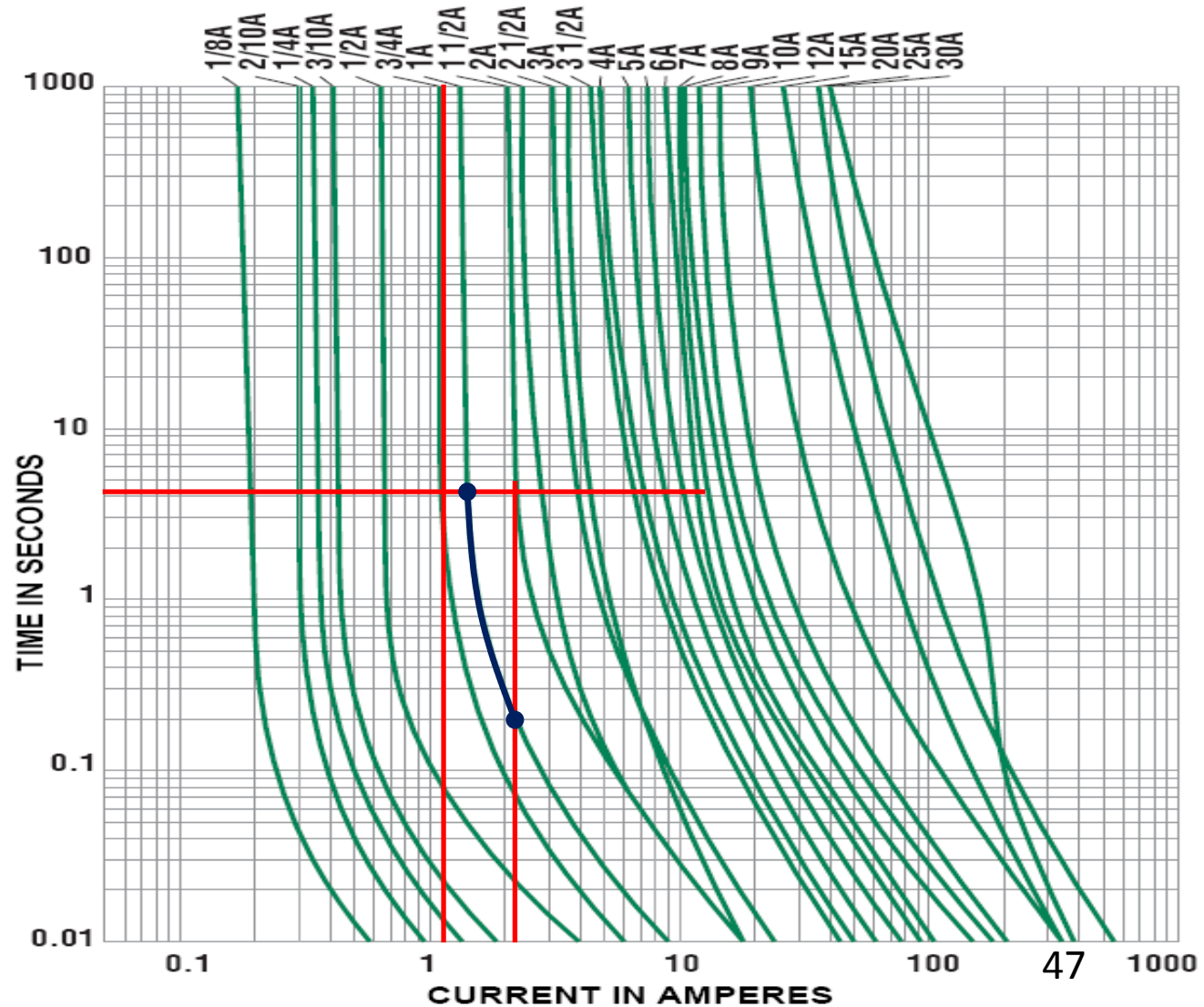

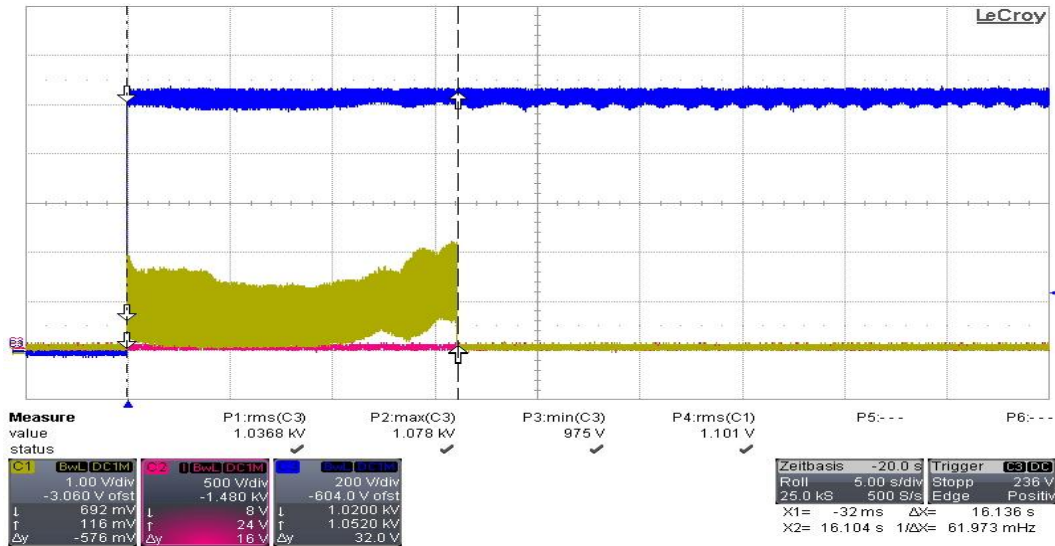

I max: 2.4A  
I mean: 1.1A  
Time to disconnect: 16s

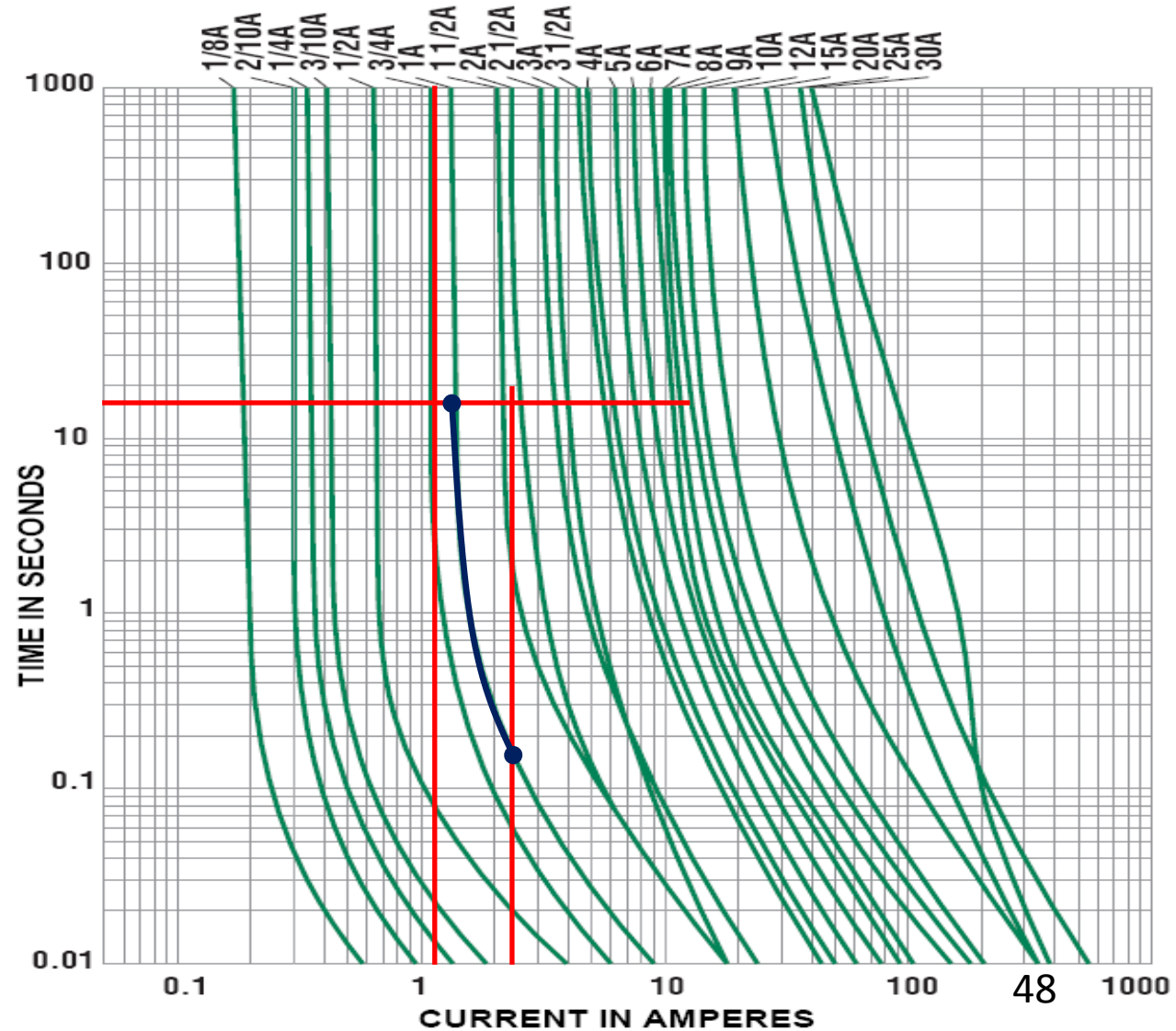



# Reminder about fuses withstand

Surge 8/20

**$I_{max}$**

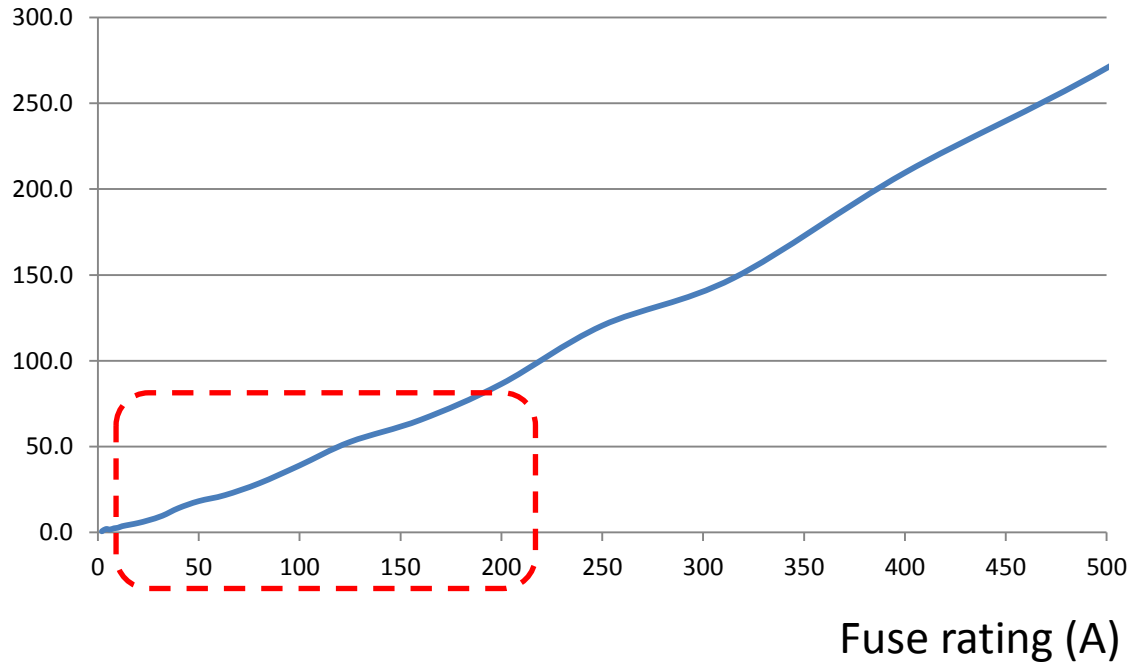

Surge 8/20

**$I_{max}$**

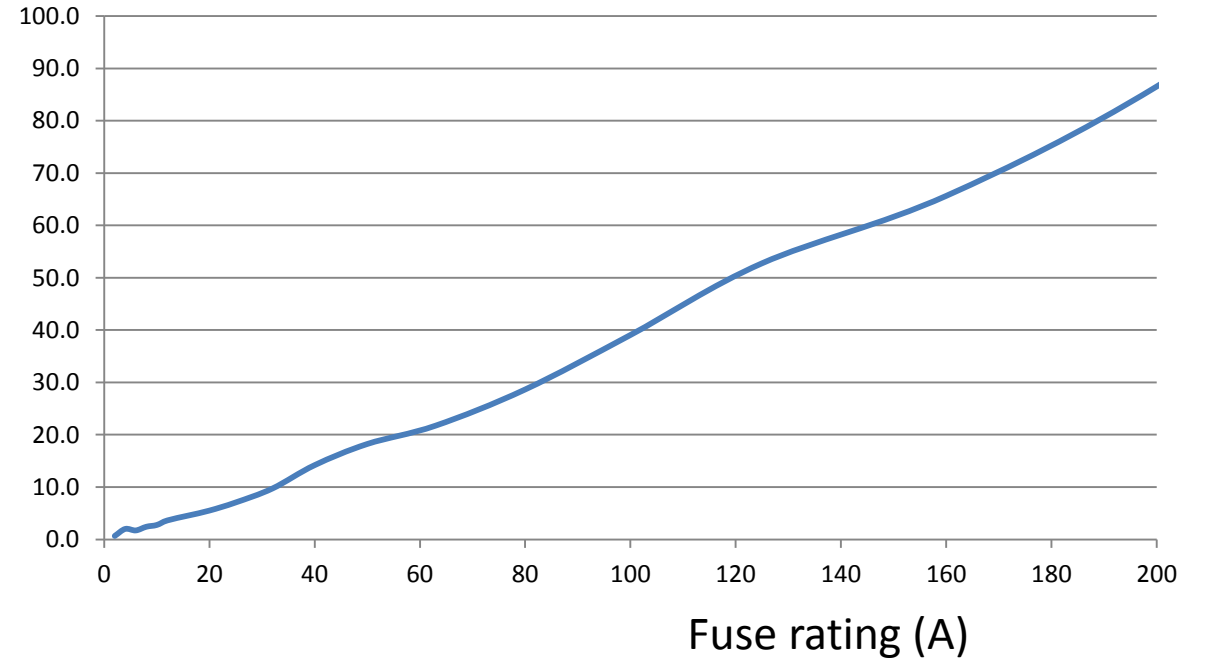

## SPD in ungrounded DC system

- To disconnect, the thermal switch (and or the over current protection if existing) needs current, energy from the source to operate.
  - In floating system, no (or very limited) current is supposed to flow via the ground connection. Then SPDs providing disconnection system not using the power source from (+) to (-) are not acceptable. Because as no disconnection is able to work, the SPD turns the ungrounded DC system in grounded system without any indication of the SPD leading to service interruption and uncontrolled safety situation.

## SPD in ungrounded DC system

- SPDs are connected to lives and to Ground... Then:
  - Is there a risk of permanent or temporary short circuit condition for SPD between lives and Ground?
  - Is the time to disconnect of the SPD compatible with chock hazard (human protection) requirements when SPD reaching its EOL?
  - Is SPD failure leading to service interruption acceptable ?

## Shock hazard protection principles

- To prevent shock hazard it is a must to disconnect the power source in case of earth fault when possible touch voltage can be higher than 120V DC

## Shock hazard protection principles

- Disconnection shall occur within a limited time

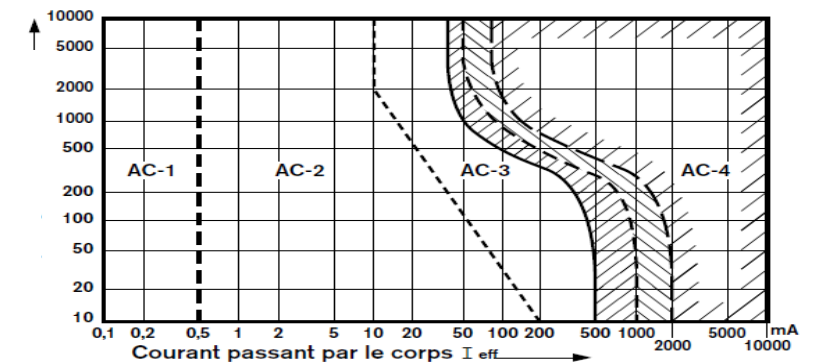
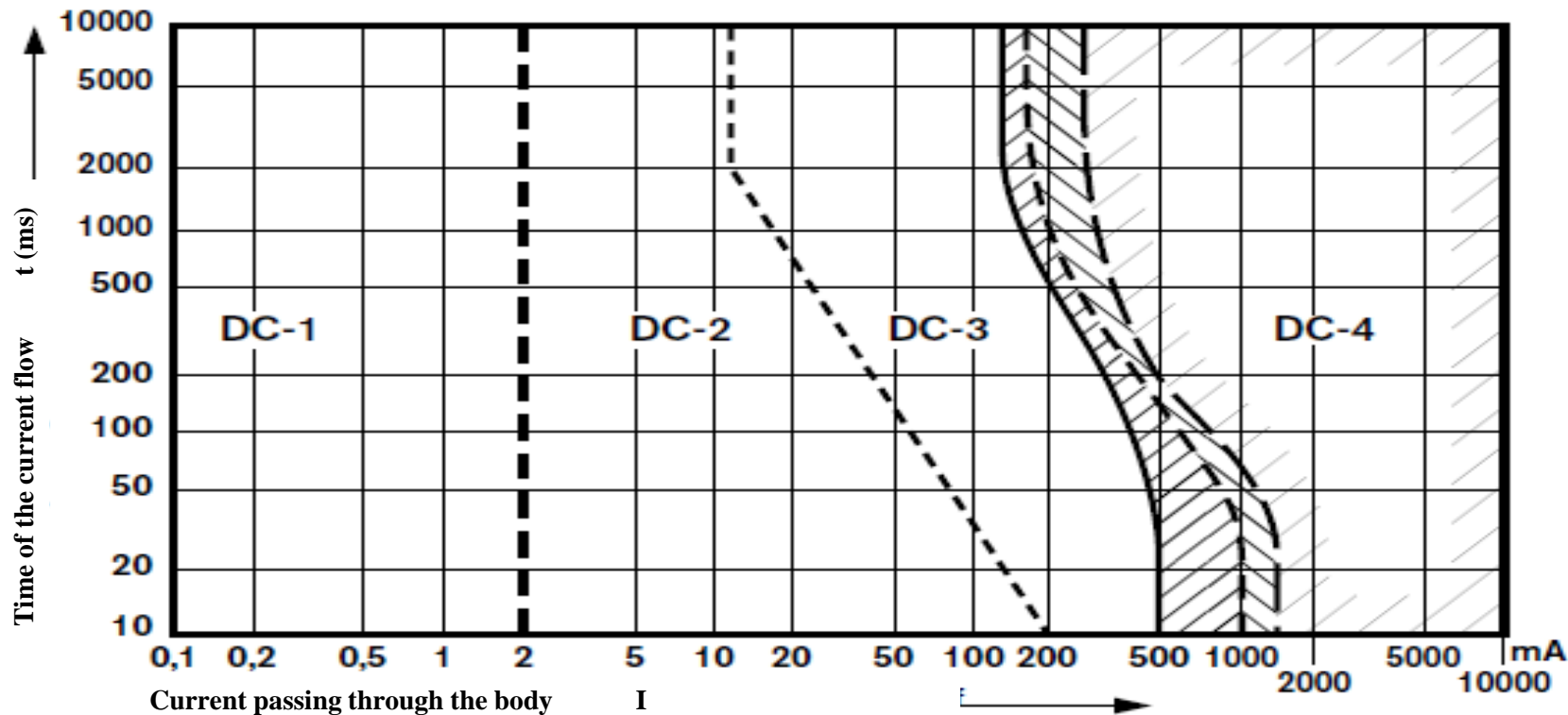

AC/DC-1: No perception

AC/DC-2: Perception

AC/DC-3: Recovery possible (Muscles contraction)

AC/DC-4: Possible unrecoverable effects

## Shock hazard protection principles

Curve showing the maximum time to disconnect depending on possible touch voltage

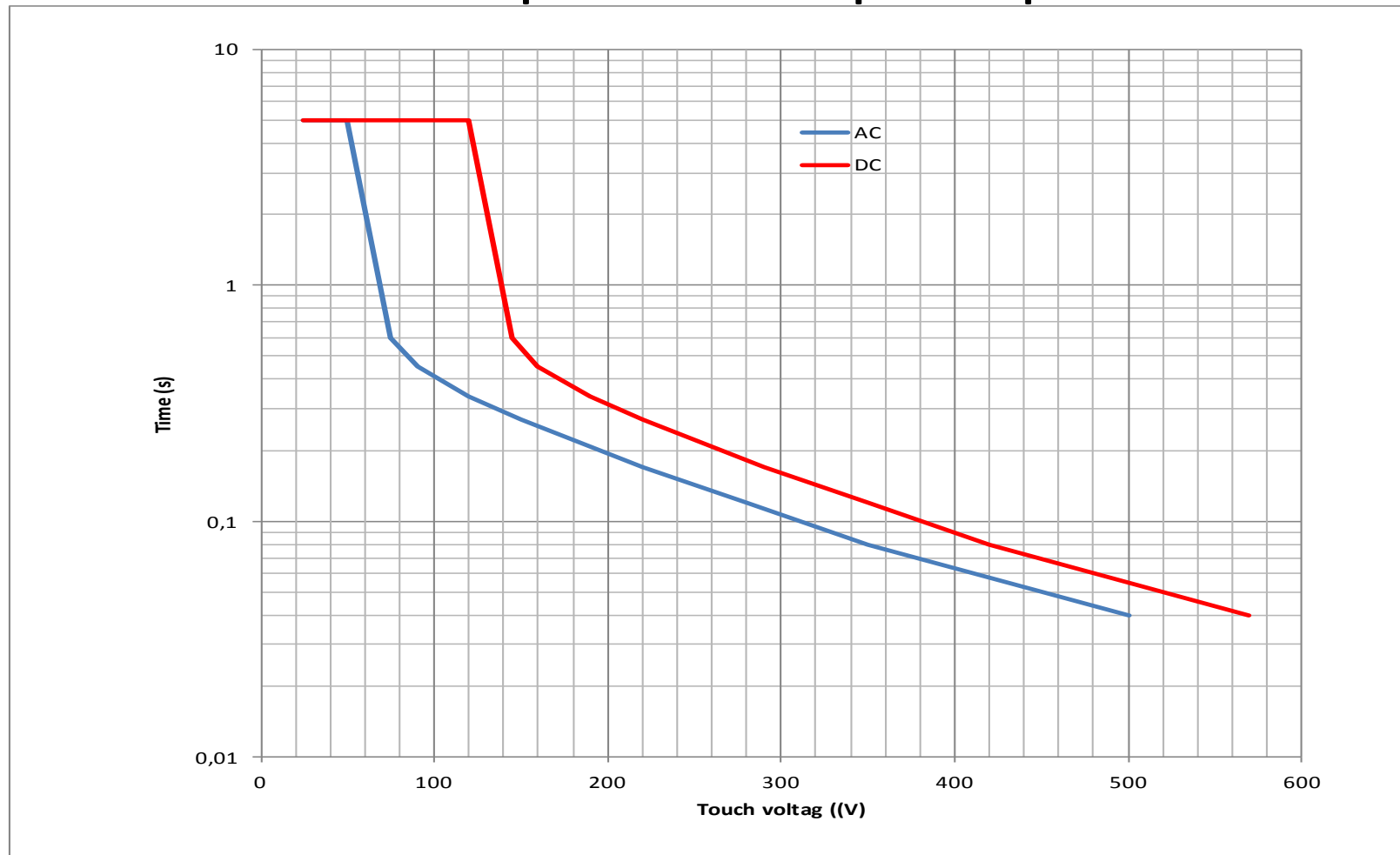

## Shock hazard protection principles

411.3.2.2 The maximum disconnection time stated in Table 41.1 shall be applied to final circuits not exceeding 32A.

**Table 41.1 – Maximum disconnection times**

System	$50 \text{ V} < U_o \leq 120 \text{ V}$ s		$120 \text{ V} < U_o \leq 230 \text{ V}$ s		$230 \text{ V} < U_o \leq 400 \text{ V}$ s		$U_o > 400 \text{ V}$ s	
	a.c.	d.c.	a.c.	d.c.	a.c.	d.c.	a.c.	d.c.
TN	0,8	Note 1	0,4	5	0,2	0,4	0,1	0,1
TT	0,3	Note 1	0,2	0,4	0,07	0,2	0,04	0,1

## Surges sources

- Switching

There is more chance that the energy stored in the wiring (of the DC system) is higher than for AC power. For 48V system it is common to see high current (few hundreds of Amperes... Interruption of this kind of current is also an aggravating factor for the switching generated surges

- Natural

Cooper remains.... Surges due natural lightning events because of coupling, conducted, GPR etc. can be predicted with same tool that are used for AC power supply.



## Surge from switching

- Differential Mode

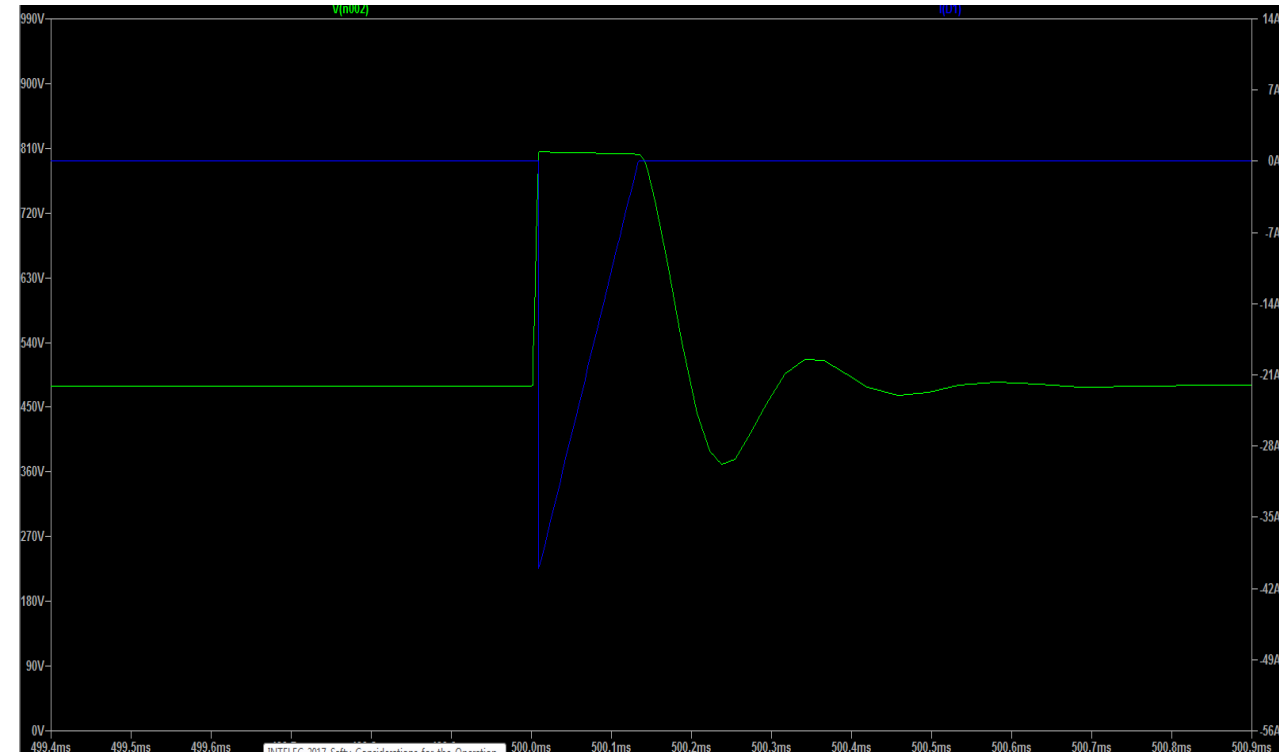
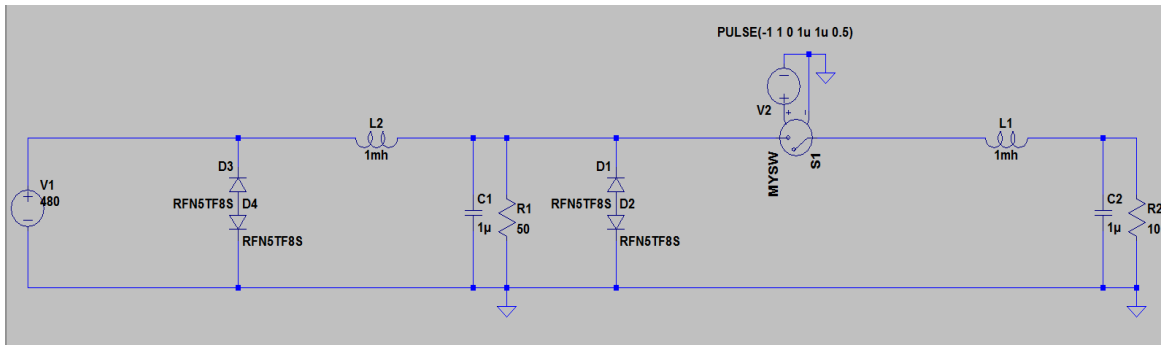

## Surge from switching

- Differential Mode

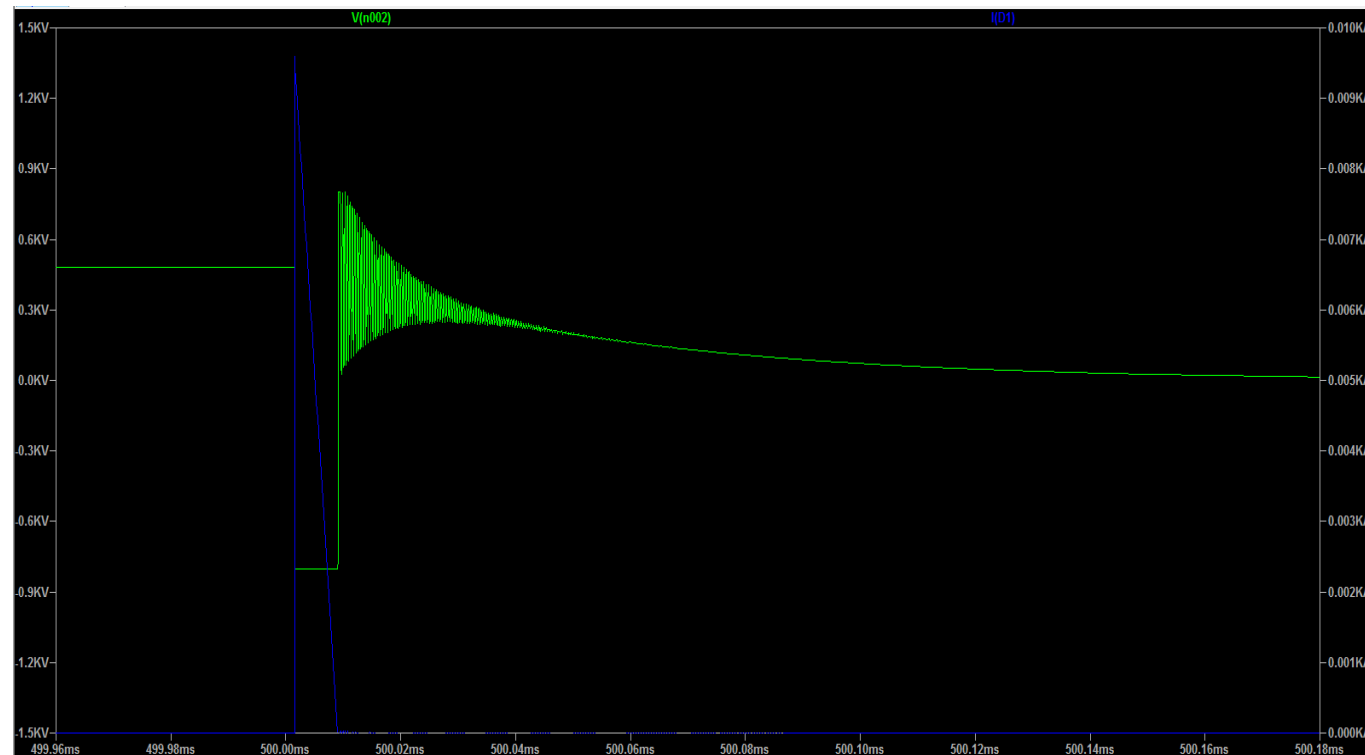
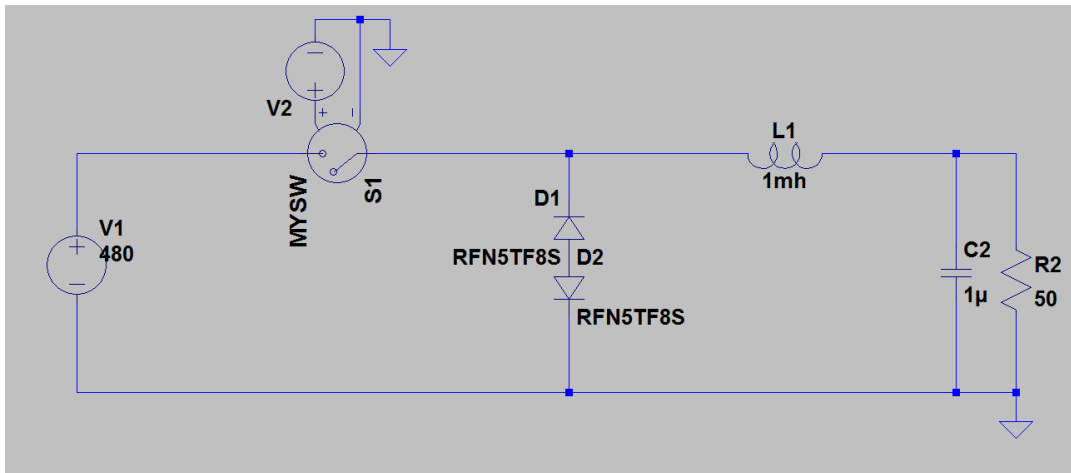

## Grounding of DC systems

- This grounding connection is usually unique and not repeated all along the cable from the inverter to the PV generator → Oscillation phenomenon or coupling aspect able to create dangerous surges if no additional SPDs
- Oscillation phenomenon or coupling have to be considered. Principles already described in published lightning and surge protection standards.
- → Surge protections mode: (+) & (-), (+) & PE and (-) & PE

## Surge modes of protections

- Common Mode

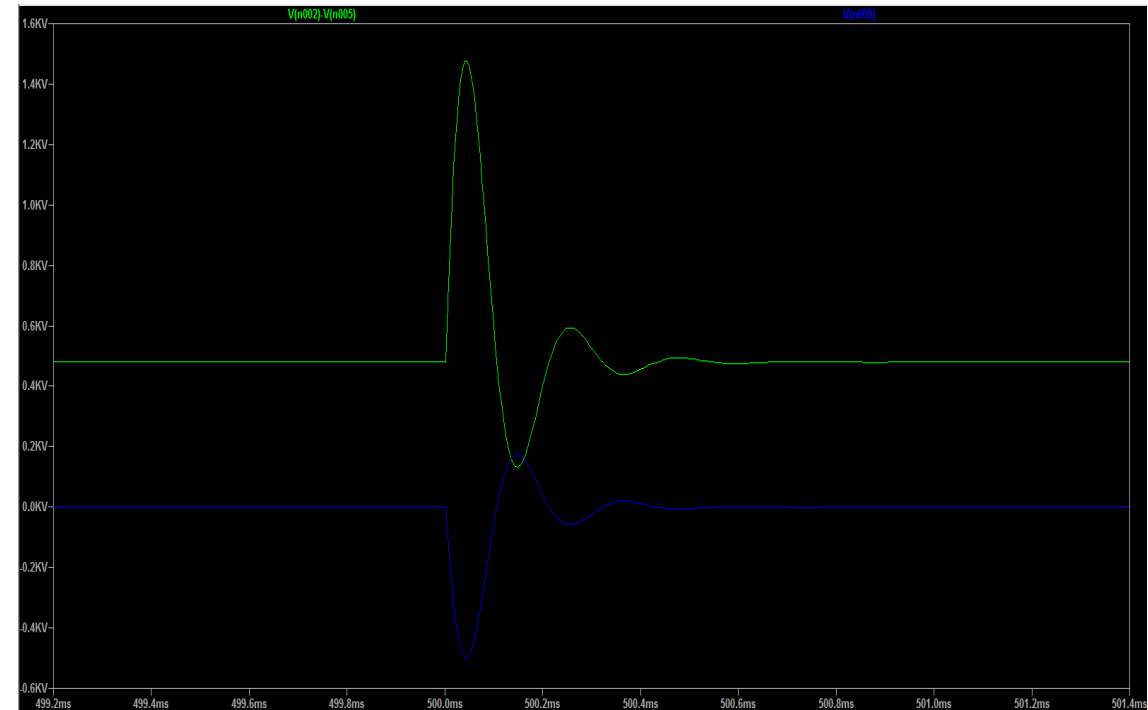
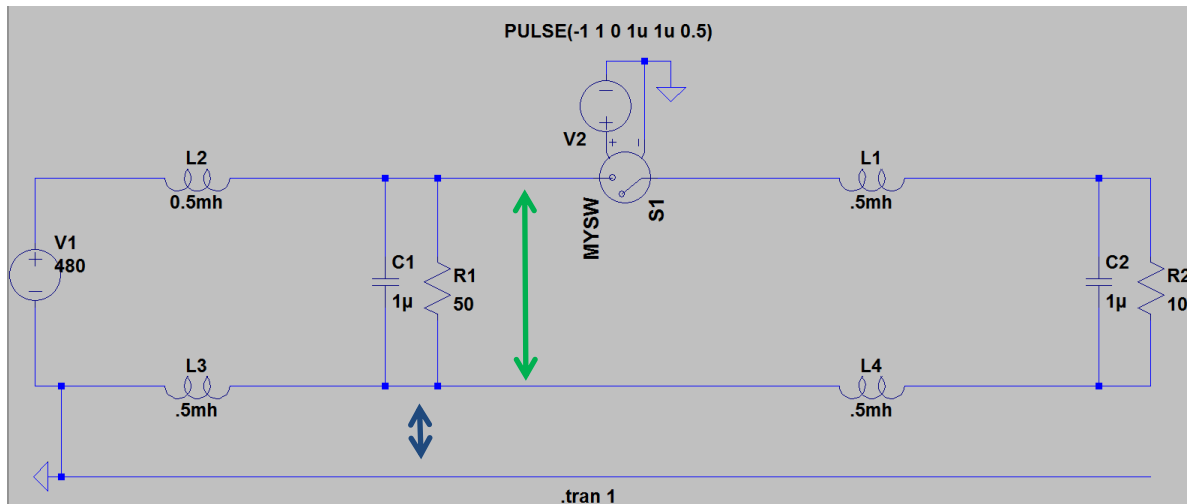

## Surge modes of protections

- In spite of the different grounding system appearances, all protection modes are always needed. Thus protection level is requested between these connection leads:
  - (+) to (-)
  - (+) to G
  - (-) to G

## Conclusion

- Power Source to be known
- Test Standard address more the linear DC power sources
- Touch voltage in DC is also critical
- SPD All modes of protection required
- SPD EOL to be known
- External protection required even if not mandatory
- Surge rating for DC SPD follows same rules than AC but Switching surges can be more stressful
- ...