

Fault Managed Power Systems (FMPS)

Ernie Gallo
Director-Network Infrastructure Solutions
Ericsson

Sponsored by:



Session 4: *New Powering Solutions*
March 24, 2022

The Power of 5G - Powering Options for Small Cells and Protection Requirements

- To continue to meet the goal of ubiquitous 5G service, it is clear that many additional 5G nodes are needed. To support these nodes, which are comprised of radios, antennas and transport equipment, additional transport backhaul, and additional power are both needed. To meet the transport bandwidth demand, fiber is often the best choice.
- To serve these sites with power, there are a few competing alternatives. You could connect each 5G node to the commercial AC power through a utility-provided metered grid connection, just as you would in your home. But providing an AC meter at every pole or site that serves as a 5G node could greatly increase cost of deployment and installation time. Another option is a direct utility connection without a meter. Such an approach requires less hardware and expense but still requires an agreement with the local power utility and the payment of a fixed fee to them. Both of these options involve the powering of telecom equipment with potentially hazardous commercial AC power.
- For 5mm wave 5G you may see equipment requiring 1,200 to 1,500 watts per node and signal propagation of only 1,000 feet.

Main Drivers for Small Cell Deployments

- Continued increase in demand for mobile data
- 5G Spectrum
- Coverage
- Capacity
- Densification
- Deployment of mm Wave spectrum
- Ultra Reliable Low Latency Communication (URLLC) applications
- Edge computing

Different Flavors of 5G

- **Lower-band 5G** provides a blanket layer for wide coverage, sometimes referred to as the coverage layer. Low-band refers to frequencies below 1 GHz used to roll out substantial 5G coverage as quickly as possible. A low-band cell site can cover hundreds of square miles as well as deliver a downlink data rate from 30-75 Mbps download.
- **Mid-band 5G** is suited to provide solutions in major metropolitan areas. Mid-band 5G uses mid-range frequencies (spanning 1 GHz and 6 GHz) that strike a balance between coverage and capacity, with operators currently deploying 2.5 GHz in the U.S. This is sometimes referred to as Sub-6 or Sub-6 GHz 5G and provides service over a fairly large service areas and provides download speeds around 115-223 Mbps.
- **High-band or millimeter Wave (mmWave) 5G** is also well suited to provide high-speed connectivity in major metropolitan areas. Peak speeds of nearly 1 Gbps, and upload speeds near 50 Mbps.



What Is a Small Cell?

Small cells are low-cost radio access points with low radio frequency (RF) power output, footprint and range

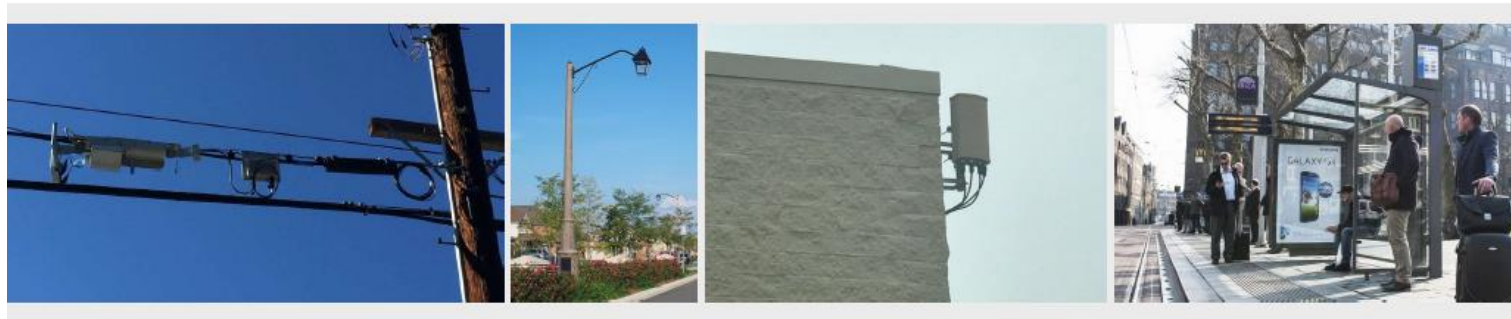

- Typically mounted on or in variety of places including poles, on walls, or within “street furniture”

- Types of small cells:

Micro Cells

RRH/RRU/Street Macro



Compromise between radio site optimization and infrastructure availability



Power meter – cost and location



Utility power availability



Timing of the permitting and approval processes



Cost of power tap



Lack of control over the approval and deployment process



Time for utility to provide power



Future expandability

- AC power directly into the radio
- DC power supply unit for RRH/RRU



PROS

- ✓ Very simple installation
- ✓ Well understood, existing standards
- ✓ Readily available in many cases

CONS

- ✗ AC power may not align with small cell location
- ✗ Every radio needs a power drop
- ✗ Time to permit and/or run new power lines can be lengthy
- ✗ Backup will be expensive from a TCO perspective for each site

Small Cell Densification

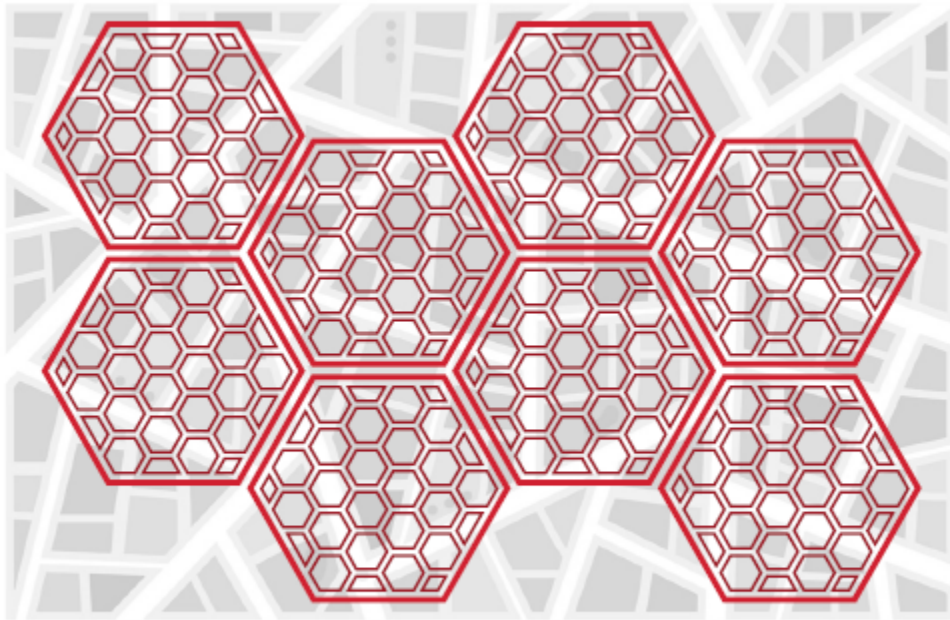

Bandwidth demand →
new spectrum (mid/mm), densification

High Power Demand

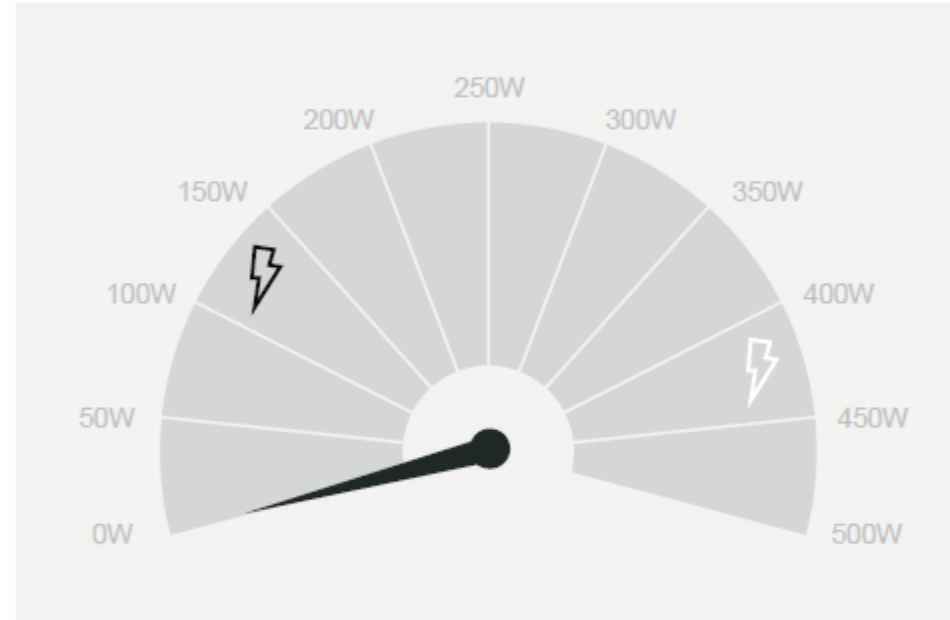

Power hungry radios →
Current safety standards limit safe power distribution

Sponsored by:



Session 4: New Powering Solutions
March 24, 2022

- 90VAC / 120VAC Outputs up to 320Watts
- Outdoor-hardened CableLabs certified DOCSIS 3.1 cable modem
- Strand, pedestal, pole, vault, and wall deployments



PROS

- ✓ Strand mount w/o additional permitting time and money (franchised)
- ✓ Backup available at most locations
- ✓ DOCSIS used for communications

CONS

- ✗ Access limited to MSOs
- ✗ 90VAC has distance limitations and requires custom power input to the radio
- ✗ Not suitable for large power loads

RFT-V Power (Remote Feeding Telecommunications, Voltage Limited)

- Elevated voltage: +/-190Vdc
- Power limited to 100W per circuit

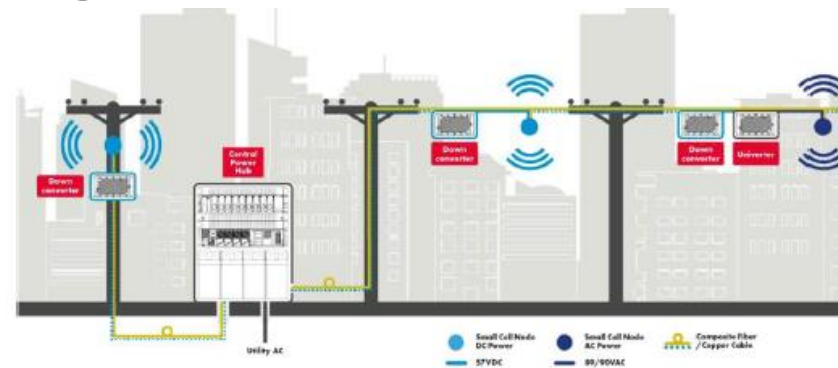

PROS

- ✓ Long standing safety standard
- ✓ Accelerates network build schedule
- ✓ Ability to reduce power tap cost
- ✓ Backup easily implemented and managed

CONS

- ✗ Larger loads require many 100W circuits
- ✗ Inefficient use of copper conductor

Evolution of centralized powering techniques

Since ~1893, Analog telephone circuits have relied solely on limiting voltage to nominal 48Vdc to mitigate shock hazard. Very limited power delivery capability over typical loop lengths.

Beginning in the 1970s, digital telephone services require more power. RFT-V allows for up to 400Vdc but limits power to 100VA per circuit to mitigate shock hazard. Limited power per circuit requires multiple circuits per Network Element. Cumbersome and inefficient.

Today's 5G cellular radios require much greater power to deliver increased bandwidth and reduced latency while covering a small propagation footprint. FMPS technology provides the capability to efficiently transport higher power levels while eliminating shock hazard. FMPS technology precisely controls and limits energy transferred during a fault. No limit for power delivered to a load.

A new powering alternative

- The 5G communications provider can employ a centralized powering approach to support 5G network deployment. A centralized powering solution leverages a single connection to the commercial power grid to deliver power to multiple remotely located network elements that can be installed thousands of feet away from the centralized power source.
- Technological advancements in power distribution system fault management techniques have made it possible to transport greater magnitudes of power while greatly reducing the risk of human shock and fire hazard.
- Fault managed power systems (FMPSs) employ sophisticated monitoring and controls, including an electronic handshake to verify that the powered device (PD) is present and operating correctly before greater than Class 2 power is applied to the circuit.
- Some versions of FMPS technology combine DC power and packetized data, which is transmitted and received between power sourcing equipment (PSE) and powered devices (PDs). Other emerging technologies utilize proprietary techniques to rapidly detect any fault condition and immediately shut down the source voltage. Both methods permit higher voltages which allow efficient power transmission over much longer distances without reliance on high currents and large gauge copper wires. Both approaches provide dramatic safety improvements over conventional power distribution methods.
- Will be installed in the communications space.

A new powering alternative

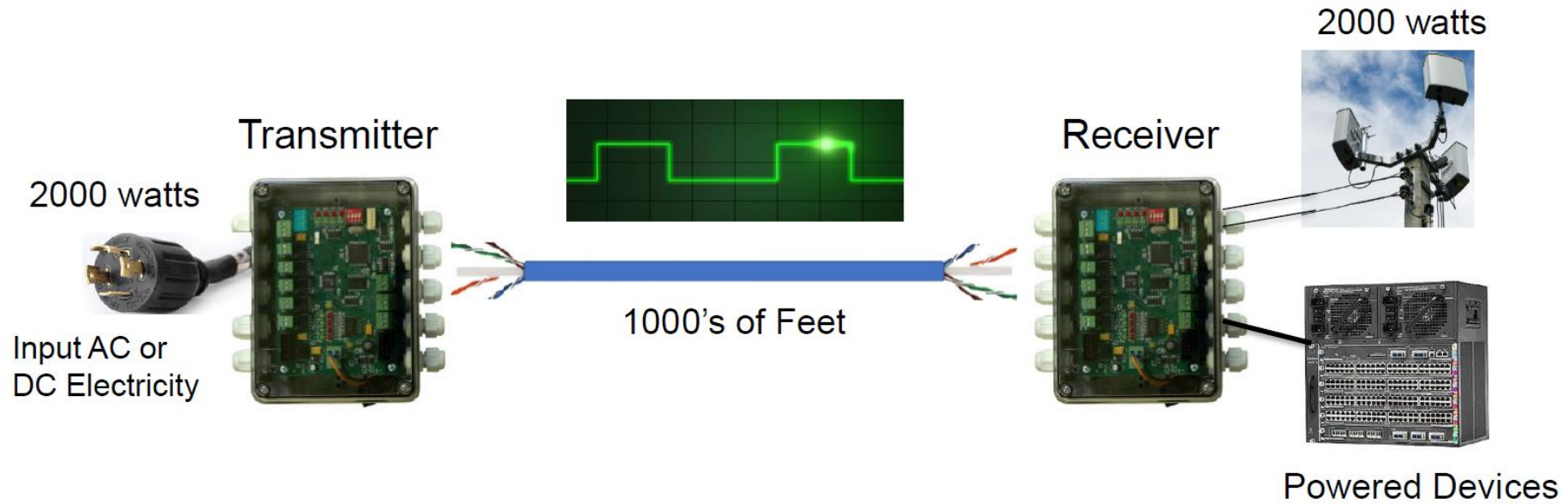

Sponsored by:



Session 4: New Powering Solutions
March 24, 2022

Power Topologies

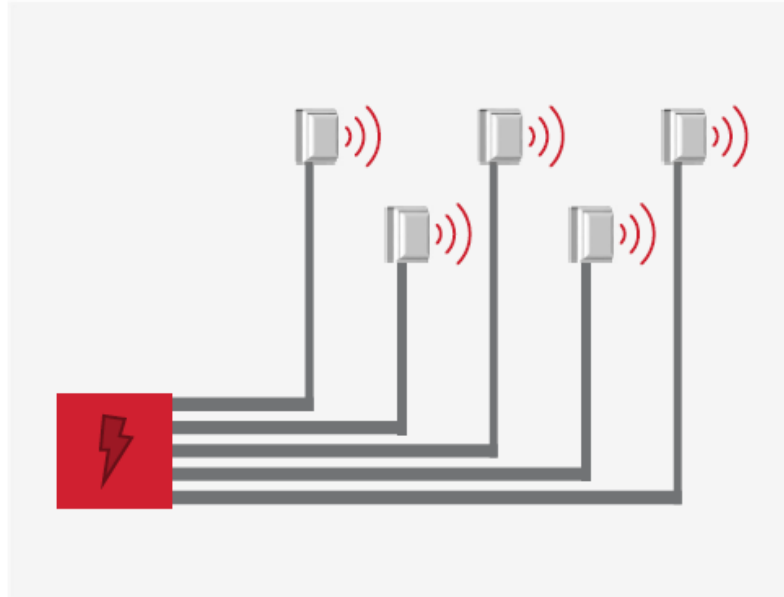

Point to Point Topology

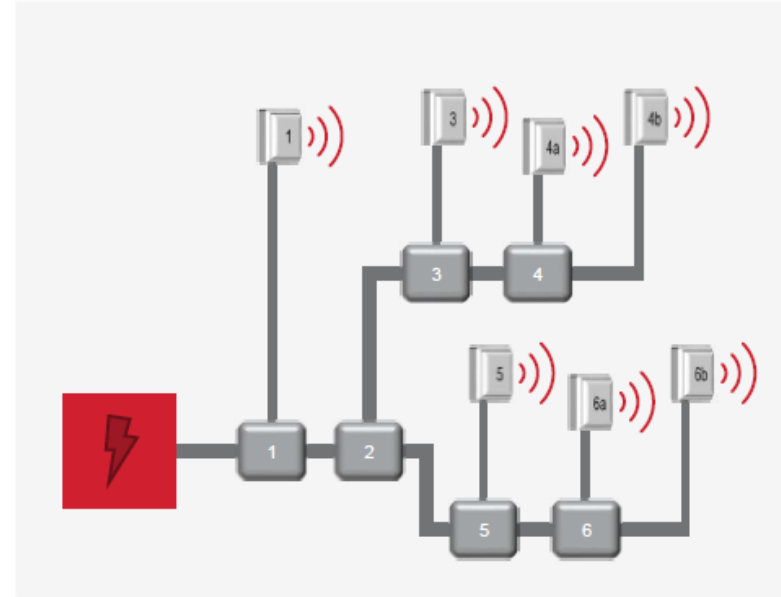

Bus Topology

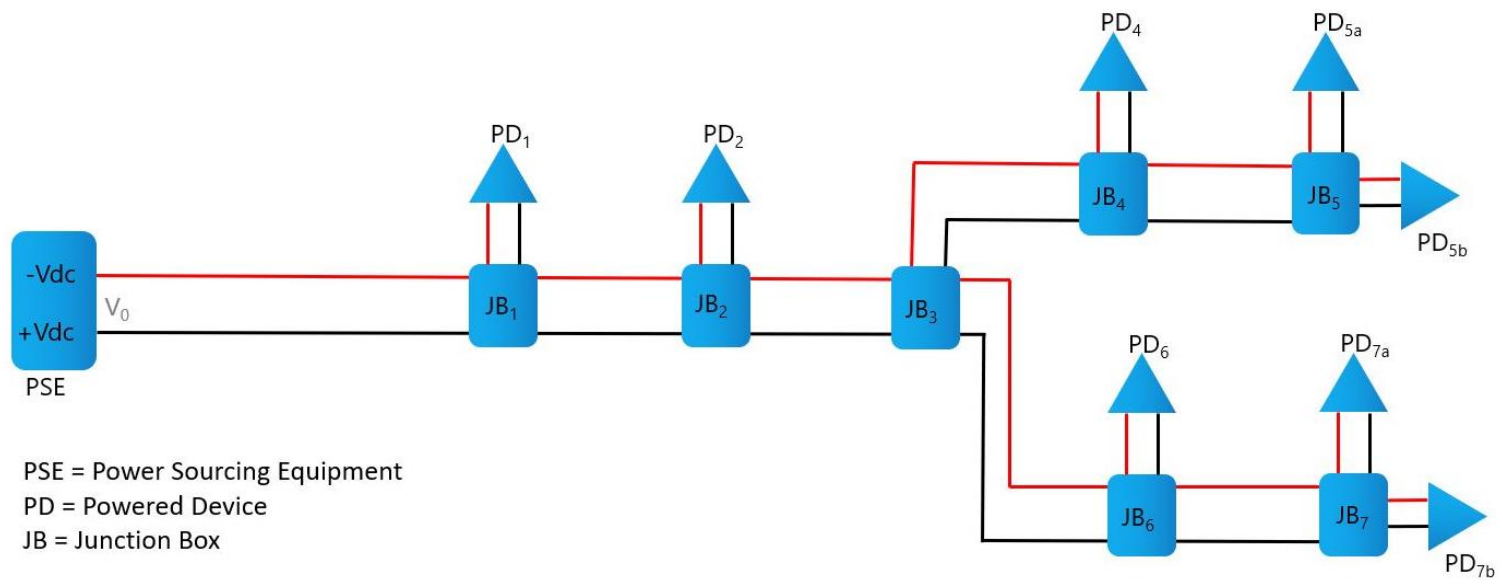
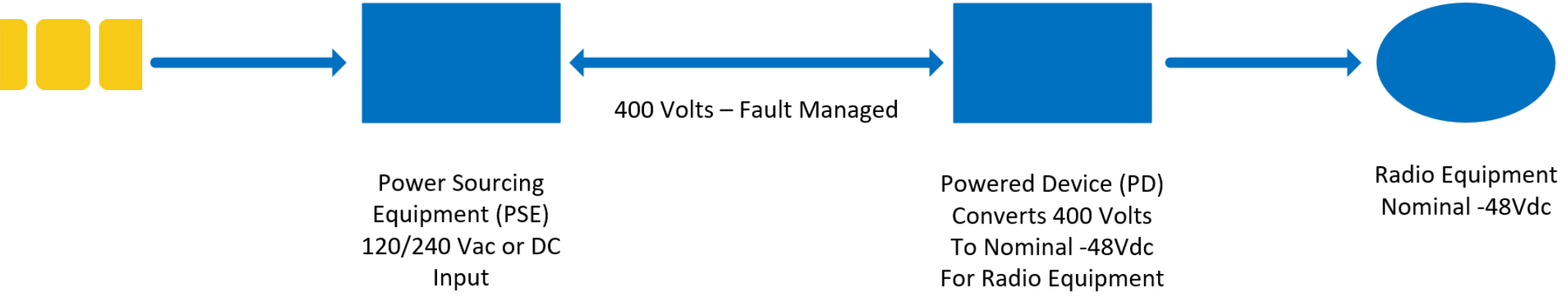

PSE = Power Sourcing Equipment
PD = Powered Device
JB = Junction Box

Sponsored by:



New Powering Solutions
arch 24, 2022

A new powering alternative

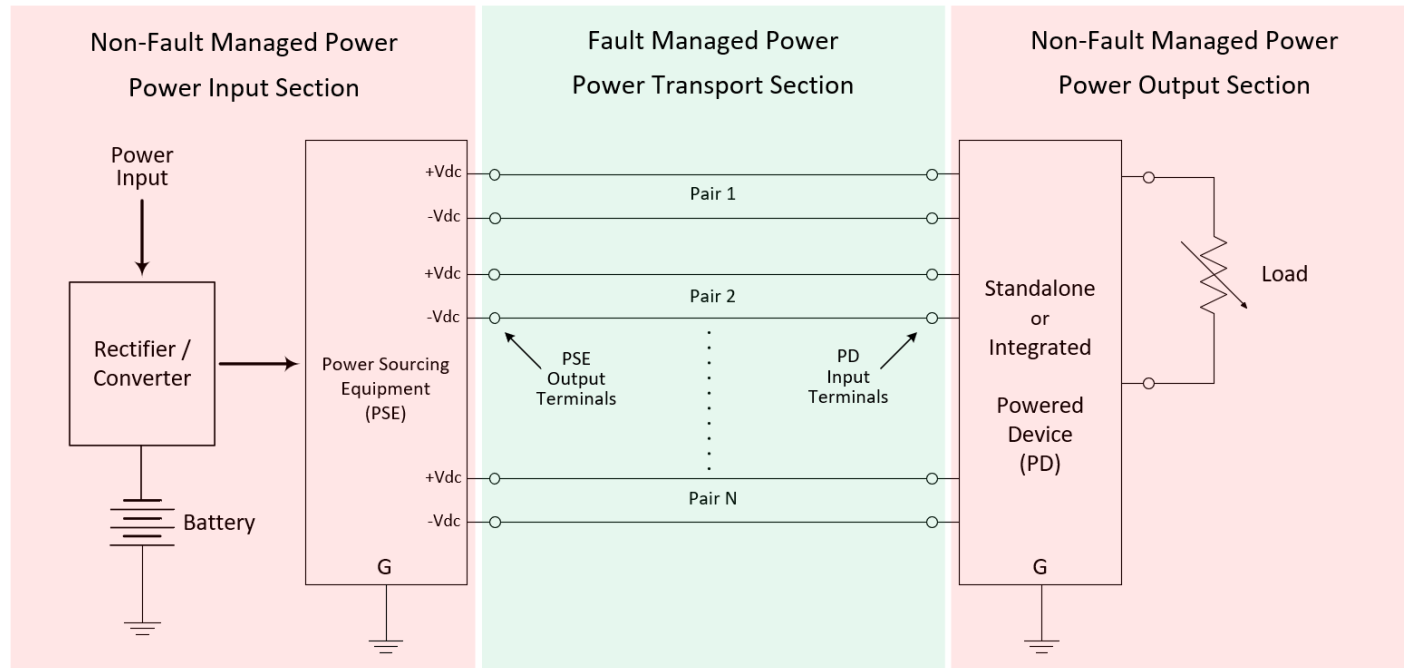

A new powering alternative

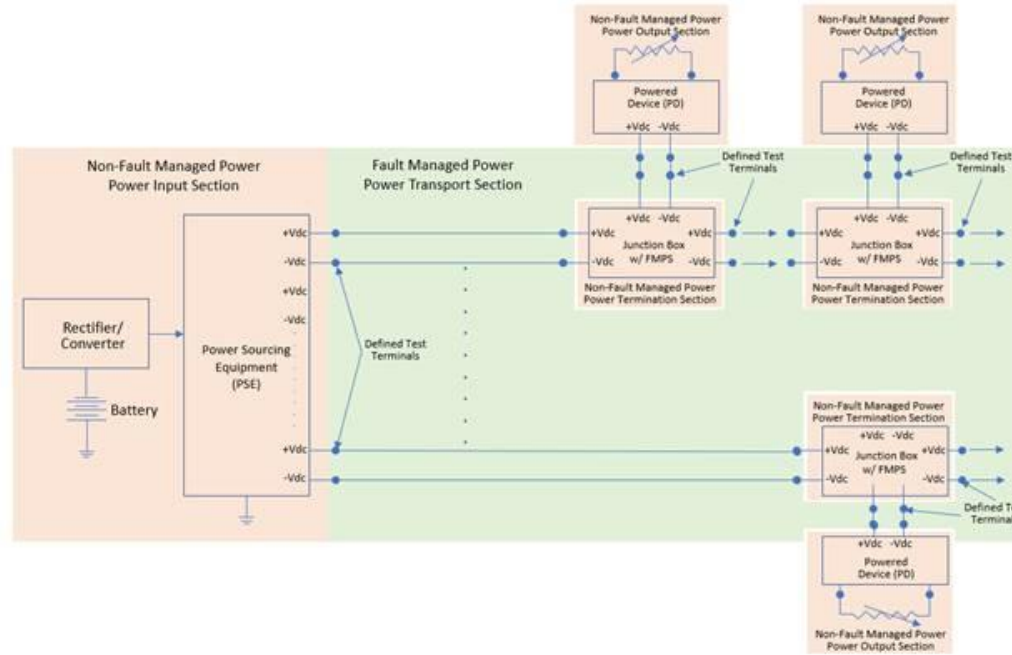

Sponsored by:



Session 4: New Powering Solutions
March 24, 2022

A new powering alternative Facilitates efficient centralized battery back-up



Sponsored by:



Session 4: *New Powering Solutions*
March 24, 2022

FMPS Advantages

- Advanced intelligence for rapid system shut down in event of a fault (shut down <10ms)
- Groundbreaking advances in power distribution technology allow for rapid detection and shut down of source in the event of human contact
- Energy transferred during a fault event is precisely controlled and limited to prevent electric shock hazard
- Isolated power channels per node for fault management & maintenance
- Higher system level efficiency
- Power Line Communications provides the operators complete visibility into power demand of each connected radio
- Remote power cycling of each PD output port for maintenance purposes
- Larger copper conductors (12 AWG vs 22 AWG) for higher power delivery over longer distances with fewer conductors
- Flexible energy storage support with use of bi-directional converter system

Safety and Protection Concerns

- Electric Shock
- Available fault energy
- Functional safety
- Cables
- IEC 60479-1: Effects of current on human beings and livestock –Part 1: General aspects
- IEC 60479-2: Effects of current on human beings and livestock –Part 2: Special aspects

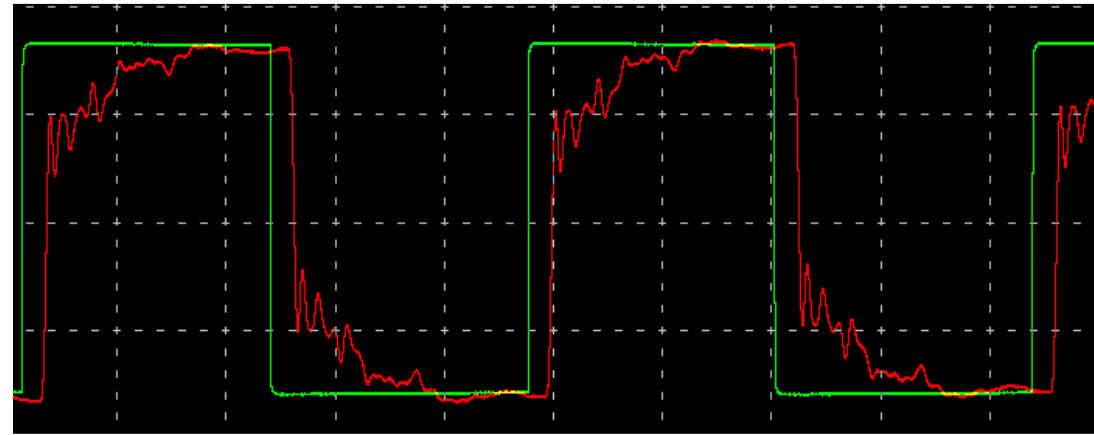

Shock Hazard

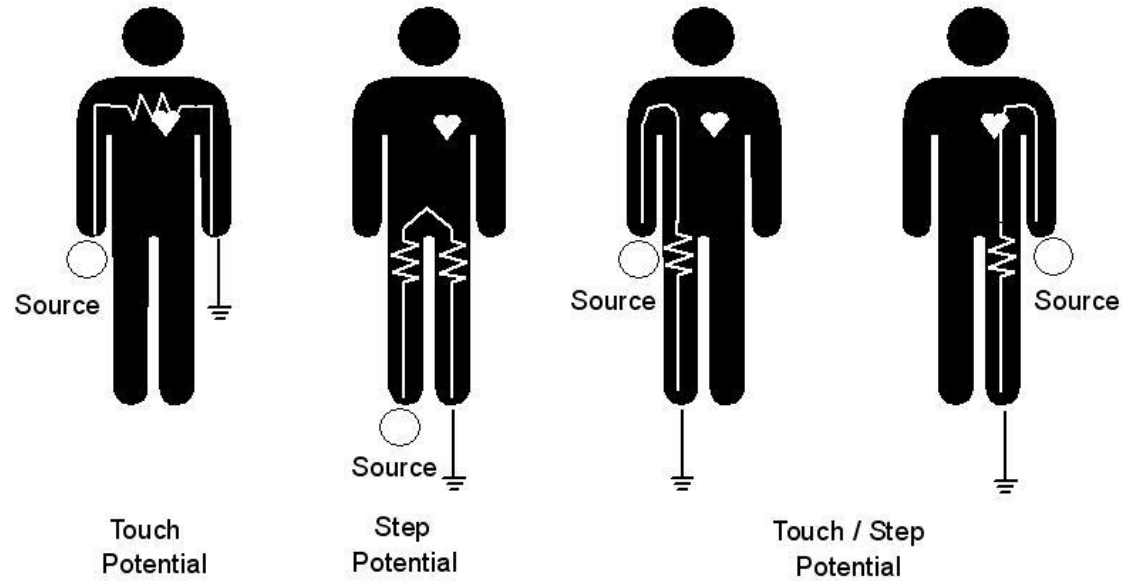

Sponsored by:



Session 4: New Powering Solutions
March 24, 2022

1 Second Exposure 60 Hz

Current	Effects
3+ Milliamps	Shock
10+ Milliamps	Muscular Contractions
30+ Milliamps	Respiratory Paralysis
40+ Milliamps	Heart Paralysis
100+ Milliamps	Ventricular Fibrillation
4+ Amps	Heart Paralysis
5+ Amps	Tissue Burning

Ventricular Fibrillation

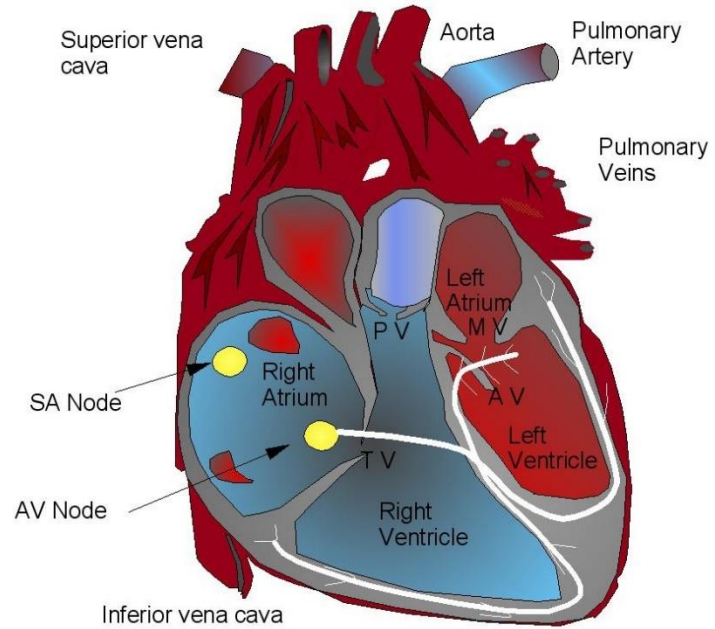

Sponsored by:



Session 4: New Powering Solutions
March 24, 2022

Let - Go

- Can cause muscles to lock up
- Varies with frequency
- Not a factor with DC
- 40 to 150 Hz are most serious
- At 60 Hz

	Females	Males
Lower limit:	6.0 mA	9.0 mA
Average:	10.5 mA	15.5 mA

Safety and Protection Concerns

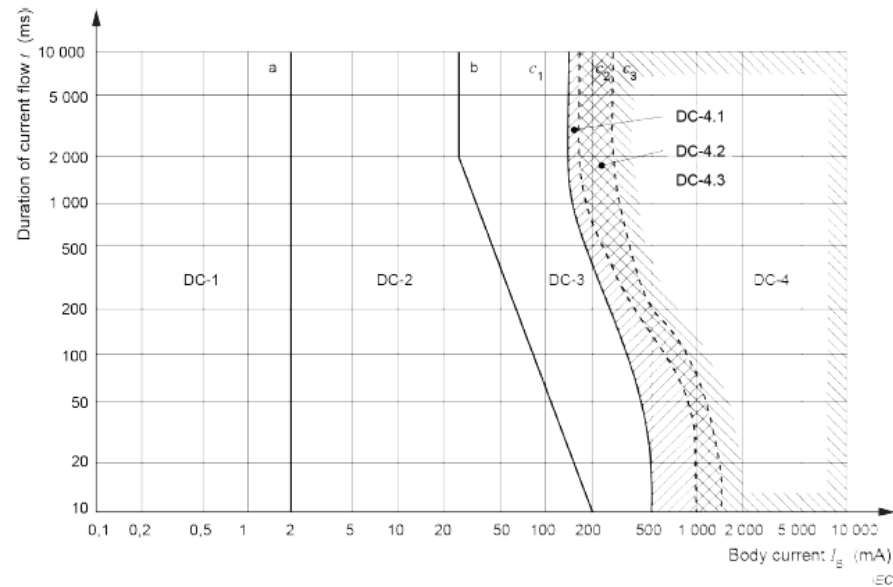

Figure 22 – Conventional time/current zones of effects of DC currents on persons for a longitudinal upward current path (see Table 13)

Safety and Protection Concerns

Shock hazard = Body current magnitude, current flow duration and current path

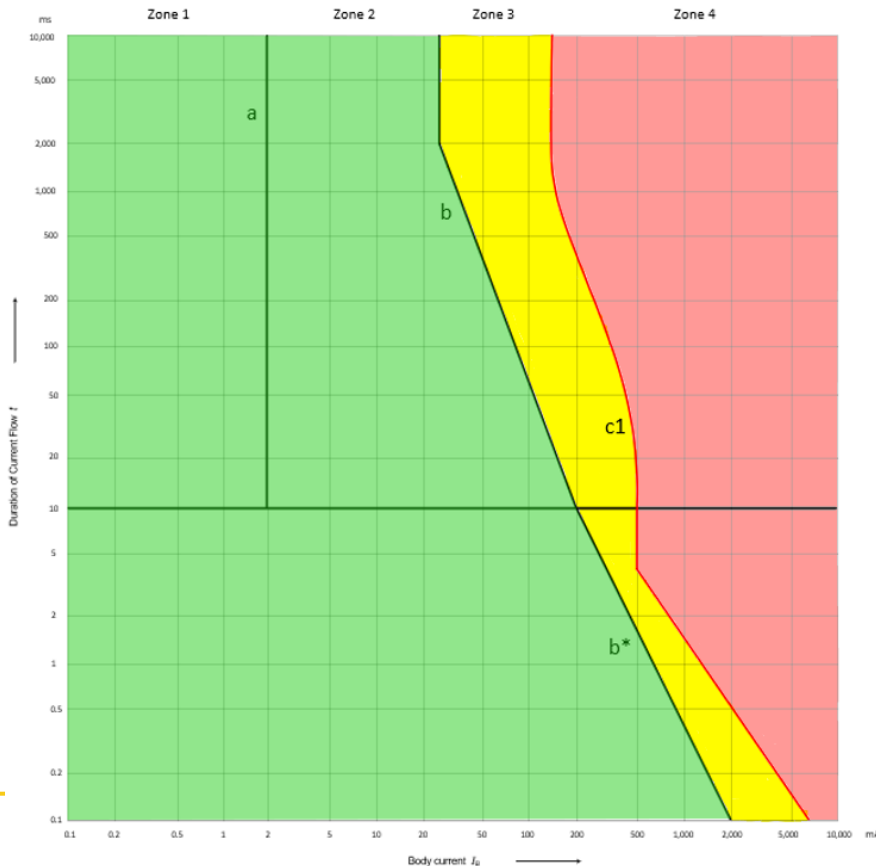

Figure 22/23 Conventional time/current zones of effects of DC current on persons for a longitudinal upward current path

Fault Managed Power Systems (CL4)
 System response to all human contact fault scenarios must fall to the left of the "b line" per ATIS Technical Report 0600040 Fault Managed Power Distribution Technologies – Human Contact Fault Analysis

Existing RFT-V Power Limited Systems
 System response to some human contact fault scenarios can reside in DC Zone 3 (to the right of the "b line") under certain fault conditions even though each circuit is limited to 100VA. Hundreds of thousands of RFT-V circuits currently operating safely in the OSP environment.

Zones	Boundaries	Physiological effects
DC-1	Up to 2 mA curve a	Slight pricking sensation possible when making, breaking or rapidly altering current flow.
DC-2	2 mA up to curve b	Involuntary muscular contractions likely especially when making, breaking or rapidly altering current flow but usually no harmful electrical physiological effects.
DC-3	Curve b and above	Strong involuntary muscular reactions and reversible disturbances of formation and conduction of impulses in the heart may occur, increasing with current magnitude and time. Usually no organic damage to be expected.
DC-4 ^a	Above curve c_1 c_1 - c_2 c_2 - c_3 Beyond curve c_3	Patho-physiological effects may occur such as cardiac arrest, breathing arrest, and burns or other cellular damage. Probability of ventricular fibrillation increasing with current magnitude and time. DC-4.1 Probability of ventricular fibrillation increasing up to about 5%. DC-4.2 Probability of ventricular fibrillation up to about 50%. DC-4.3 Probability of ventricular fibrillation above 50%.

Cable Review

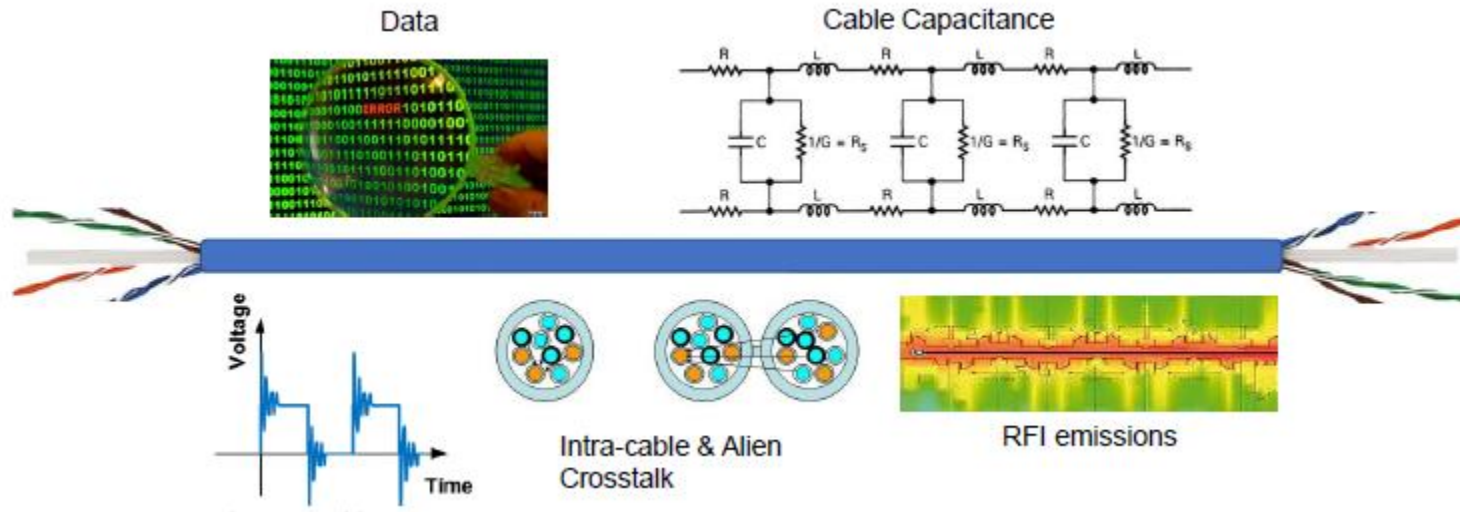

Effects of repetitive high voltage impulses on insulation

Sponsored by:



Session 4: New Powering Solutions
March 24, 2022

ATIS, NEC, UL, IEC

- ATIS Technical Report ATIS-0600040 *Fault Managed Power Distribution Technologies—Human Contact Fault Analysis*
- NEC—Article 726—Class 4 (CL4) Power Systems
- UL 1400-1 (Class 4 Equipment)
- UL 1400-2 (Class 4 Cables)
- IEC 60479-1: *Effects of current on human beings and livestock—Part 1: General aspects*
- IEC 60479-2: *Effects of current on human beings and livestock—Part 2: Special aspects*

Safety Standards

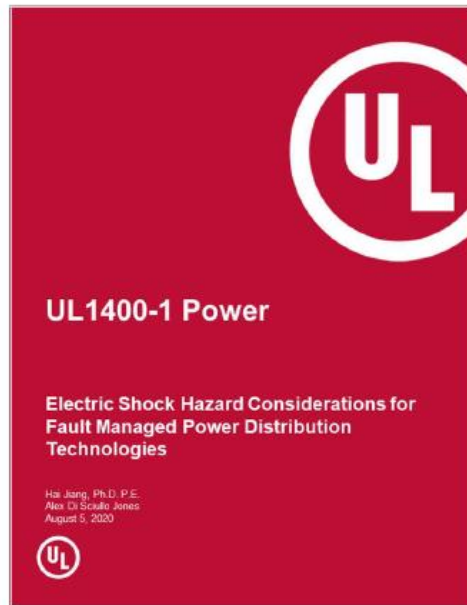

Effects of repetitive high voltage impulses on insulation

Sponsored by:



Session 4: New Powering Solutions
March 24, 2022

ATIS Technical Report 0600040

Fault Managed Power Distribution Technologies – Human Contact Fault Analysis

4 Basics of Fault Managed Power Distribution Systems

Technological advancements in power distribution system fault management techniques have made it possible to transport electrical power while reducing the risk of human shock and fire hazard. Systems that employ fault managed power distribution technology provide for rapid fault detection and power source shut down in the event of human contact under a wide range of line to ground and line to line fault scenarios. This technology precisely controls and minimizes the amount of fault energy that can be transferred to a person during a human contact fault event. While adhering to the same source voltage limits defined for RFT-V [8] technology, fault managed power distribution systems make it possible to safely deliver higher levels of power to remotely located telecommunications network elements than existing RFT-V powering methods. **No power limitation is placed on fault managed power system (FMPS) sources, however, unlike RFT-V systems, this TR imposes a limit on the amount of fault energy that can be transferred to a human during a human contact fault event.** For a FMPS to qualify as acceptable per this TR for bare handed human contact, the plotted fault test results must fall within DC zone 1 or 2 defined in Figure 22 of IEC 60479-1 [Ref 1] for fault events greater than 10 milliseconds in duration or to the left of the extended “b line” for fault events less than 10 milliseconds in duration for the entire range of total body resistance values specified in table A.1 of Annex A. The extended “b line” has been mathematically developed by Dr. Francisco Paz

UL 1400-1 Fault-managed power distribution technologies

Part 1: General Requirements

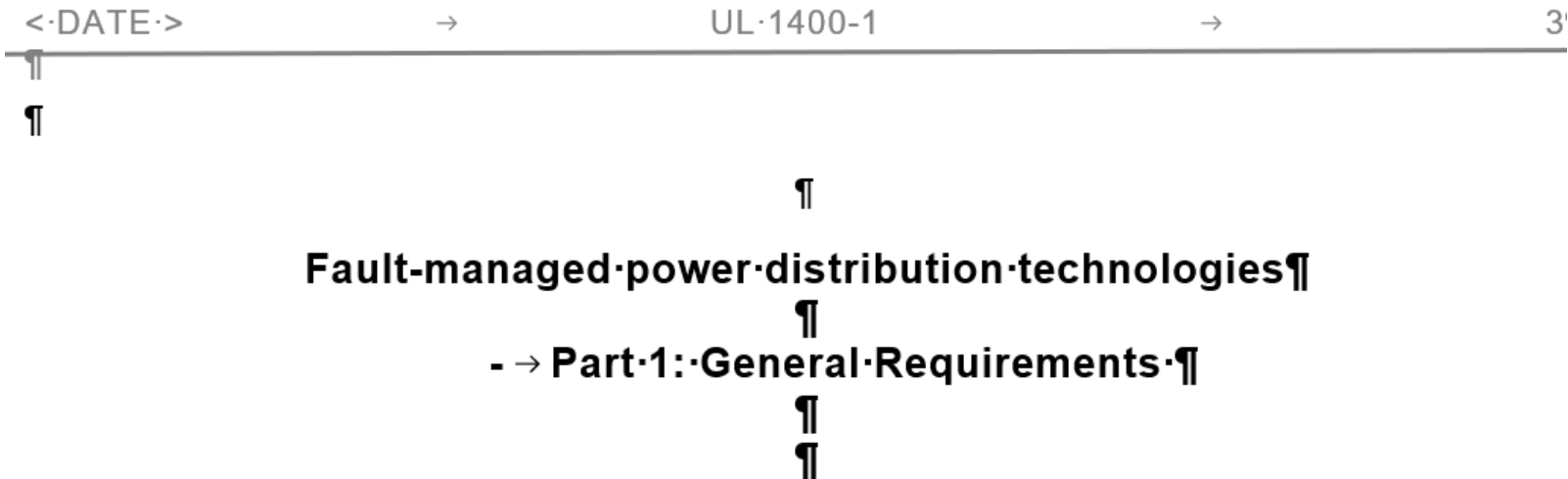

1 -> Scope

1.1 -> This Outline of Investigation specifies requirements for fault-managed power distribution systems, also referred to in the National Electrical Code® as “Class 4 Power Systems”. These systems are characterized by sophisticated monitoring and control systems that monitor the circuit for faults and control the power transmitted to ensure that the energy delivered into a fault is limited.

Class 4 power systems differ from Class 2, and 3 systems in that they are not limited at the source but are power limited with respect to risk of electric shock and fire between the Class 4 Transmitter and Class 4 Receiver.

Article 726 Class 4 (CL4) Power Systems

Part I. General

726.1 Scope.

This article covers the installation of wiring and equipment of fault-managed power (FMP) systems, including utilization equipment incorporating parts of these systems.

Informational Note No. 1: See Article 100 for definitions related to this section.

Informational Note No. 2: Class 4 power systems consist of a Class 4 power transmitter and a Class 4 power receiver connected by a cabling system. These systems are characterized by monitoring the circuit for faults and controlling the power transmitted to ensure the energy and power delivered into any fault is limited. Class 4 systems differ from Class 1, Class 2, and Class 3 systems in that they are not limited for power delivered to an appropriate load. They are power limited with respect to risk of shock and fire between the Class 4 transmitter and Class 4 receiver.

Safety Standards

Effects of repetitive high voltage impulses on insulation

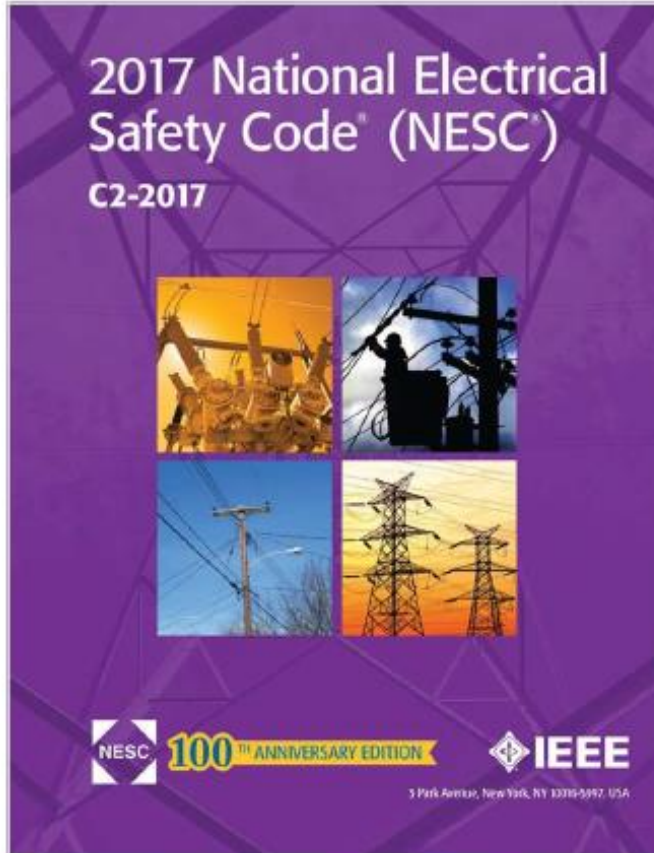

Code Updates delayed due to COVID-19. Target 2023 (1 year delay)

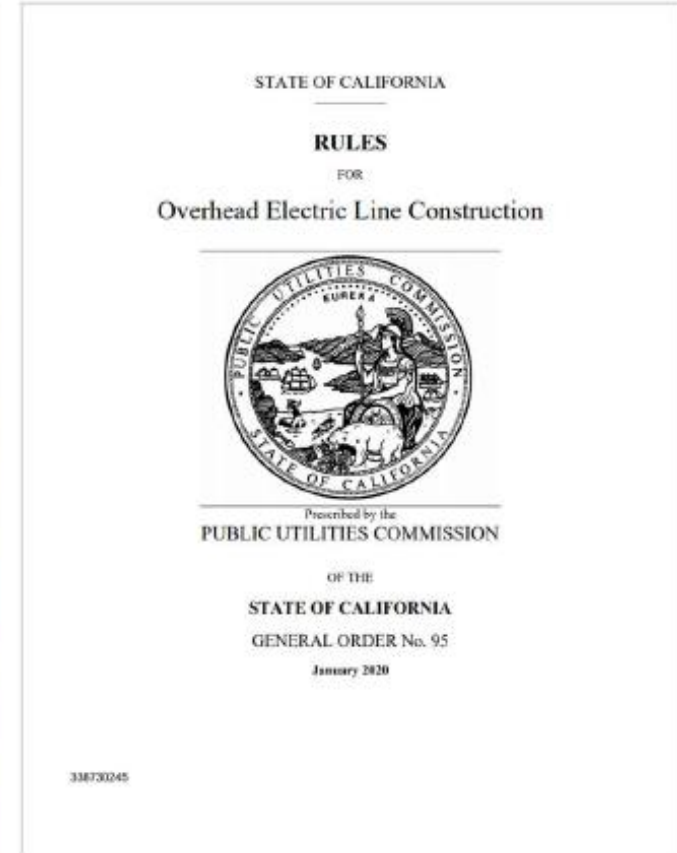

Sponsored by:



Session 4: New Powering Solutions
March 24, 2022

Functional Safety Certification Requirements for FMPS

- Ensure that safety-related control functions perform reliably to minimize risk
- Fault and failure-mode analysis
- Fail safe modes
- MTBF (critical components)
- Critical component redundancy
- Safety-related software analysis
- What if the monitoring system fails?



Additional Information

- We look to the NESC, 224 and other appropriate sections.
- The following article provides additional information:

[Powering Options for 5G Small Cells with Ernie Gallo | ISEMAG](#)